

# **Bandit IV Installation Manual**

Publication BDT4-4.1

**Important User  
Information**

Because of the variety of uses for the solid state equipment described herein, and because of the differences between it and electromechanical equipment, you must satisfy yourself as to its acceptability for each of your applications. In no event will Allen-Bradley Company be responsible or liable for indirect or consequential damages that may result from installation or use of this equipment.

The illustrations, charts, and layout examples shown in this manual are intended solely to help you understand the text, not to guarantee operation. Because of the many variables and requirements associated with any particular installation, Allen-Bradley Company will not assume responsibility for actual use based upon illustrations of applications.

No patent liability is assumed by Allen-Bradley Company with respect to use of information, circuits, equipment, or software described in this text.

Reproduction of any part of this manual, without written permission of Allen-Bradley Company, is prohibited.

© 1985 Allen-Bradley Company

TABLE OF CONTENTS

<u>Title</u>	<u>Page</u>
<u>EXPLODED VIEWS</u>	
Operator Panel .....	1
Pendant Enclosure .....	3
<u>MOUNTING DIMENSIONS</u>	
Dimensions of Processor Enclosure .....	4
Dimensions of Pendant Without Cover .....	5
Dimensions of Hinged Pendant Cover .....	6
Dimensions of the Swivel Assembly .....	7
Dimensions for the 8400-PSB Power Supply .....	8
Dimensions for the Power Supply Mounting Bracket .....	9
<u>WIRING SCHEMATICS</u>	
General System Wiring .....	10
8400 AC Power Distribution .....	11
CPU/CRT Connector Location Diagram .....	13
CPU and CRT Module Layout .....	15
Power Supply Interconnection .....	17
Power Supply Loading .....	17
CRT Video Signal Connection .....	19
Monochrome Monitor .....	19
Color Monitor .....	19
RS232 Cabling to Pendant .....	21
Handwheel Wiring .....	23
Pendant Location .....	25
Color Monitor Connections and Location .....	27
Color Signal Connection .....	27
AC Power Connection .....	27
Monochrome Monitor Connection and Location .....	29
Video Signal Connection .....	29
AC Power Connection .....	29
Pendant AC Terminal Block Connections .....	31
Front Panel Connector Location .....	32
Keyboard Interconnection .....	34
Front Panel Lamp Connections .....	36
Typical E-Stop Wiring .....	38
I/O Board Logic Supply .....	40
I/O Connection Diagram .....	42
PAL Worksheets for 24 Point I/O Board .....	43
PAL Worksheets for 24 Point Quad Pack I/O Board .....	46
Standard PAL I/O Assignments .....	49
Encoder Feedback Connections .....	52
Encoder Wiring .....	52
Drive Out Connections .....	54
Typical Drive Wiring .....	56

<u>Title</u>	<u>Page</u>
<u>CABLING</u>	
Cabling Description .....	58
AC Cable for Incoming Power to AC Distribution Terminal Block in Pendant .....	59
AC Power Cable for Color Monitor .....	60
AC Power Cable for Monochrome Monitor .....	61
AC Cable for Peripheral Panel .....	62
Video Signal Cable for Color Monitor .....	63
Video Signal Cable for Monochrome Monitor .....	64
E-Stop Cable .....	65
Handwheel Cable .....	66
Serial Keyboard Cable .....	67
Indicator Light Cable .....	68
Serial Communications Cable .....	69
<u>FINAL PROCEDURES</u>	
Configuring Velocity Loop .....	70
Encoder Wiring .....	71
Encoder Phasing .....	71
Control Power-Up .....	72

PARTS LIST FOR OPERATOR PANEL

Item	Catalog Number	Qty	Description
1	8410 BPNL	1	Bandit IV complete operator control panel with monochrome monitor (shown)
	8420 BPNL	1	Bandit IV complete operator control panel with color monitor (not shown)
2	8410 BBZL	1	Bezel assembly with 10 softkeys, gasket, and Bandit IV name plate
	Includes all of the following:		
		8	Nut hex, 8-32 W/Lkw
		1	Nut hex, 8-32
		1	Ground Strap
		2	Washer, Ext Th, #8
3	8000 XBVD	1	Monochrome monitor assembly
	Includes all of the following:		
		6	Screw, Pnh-Ph, TF-8 X .375
		6	Washer, flat #8
3	8000 XCVD		Color monitor (Not Shown)
	Includes all of the following:		
		6	Screw, Pnh-Ph, TF-8 X .375
		6	Screw, Pnh-Ph, TF-8 X .375
4	8000 XKBM	1	Keyboard electronics module
5	8410 KYBS	1	Keyboard mechanical module and keycaps

Item	Catalog Number	Qty	Description
6	8410 KYBD	1	Keyboard assembly (includes both mechanical and electronics boards)
	Includes all of the following:		
		5	Screw, Pnh-Ph 6-32 X .375
		5	Washer, Intl Th, #6
7	8000 XBBK	1	Monochrome monitor bracket assembly (shown)
	8000 XCBK	1	Color monitor bracket assembly (not shown)
Includes all of the following:			
		1	Right hand top monitor bracket
		1	Left hand top monitor bracket
		10	Nut hex, 10-32, W/Lkw
		4	Washer, flat, #10
8	8000 XESS	1	E-Stop switch assembly
9	8000 XORS	1	Feedrate or spindle speed override assembly
	Includes the following:		
		1	Knob for feedrate or spindle speed override switch assembly
10	8410 CBSS	1	Cycle start, BLK/BLK, and cycle stop pushbutton assembly <i>Bulletin 800A</i>
	Includes all of the following:		
		1	Lamp 24v 800M-N17 <i>BORDER STATE ELECTRIC</i>
		1	Cable for 8000 CBSS assembly
		3	Lock ring for pushbutton assembly
11	8000 XHP	1	Handwheel assembly
Includes all of the following:			
		3	Washer, flat #6
		3	Screw, Pnh-Ph, 6-32 X .5
		1	Knob, decal, and set screws for handwheel

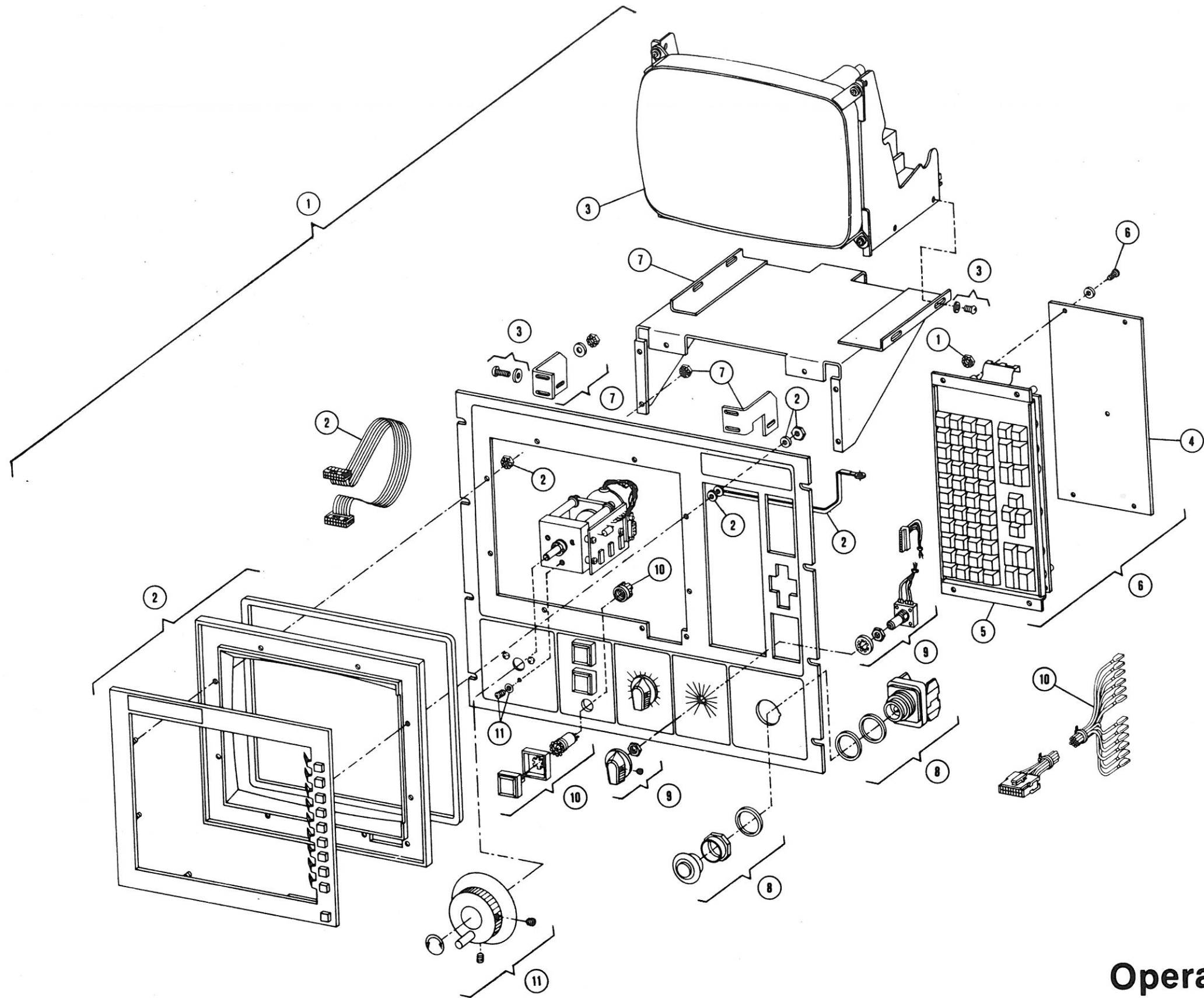

**Operator Panel**

PARTS LIST FOR PENDANT ENCLOSURE

Item	Catalog Number	Qty	Description
1	8000 XCPD	1	Complete pendant enclosure assembly
2	8000 XPPNL	1	Peripheral panel and gasket
3	8410 ACBL	1	AC cable for peripheral panel
	Includes all of the following:		
		1	Termination connector and cap and chain
		1	Mating connector
4	8410 SCBL	1	Serial communications cable for peripheral panel
5	8410 PCBL	1	Complete peripheral panel and cable set
<b>Part Number</b>			
6	915328-07	1	Air filter (6x6)
7	915328-05	1	Air filter (6x18)
8	958516-01	2	Cooling Fan
	958516-02	2	Cable assembly for cooling fans (not shown)

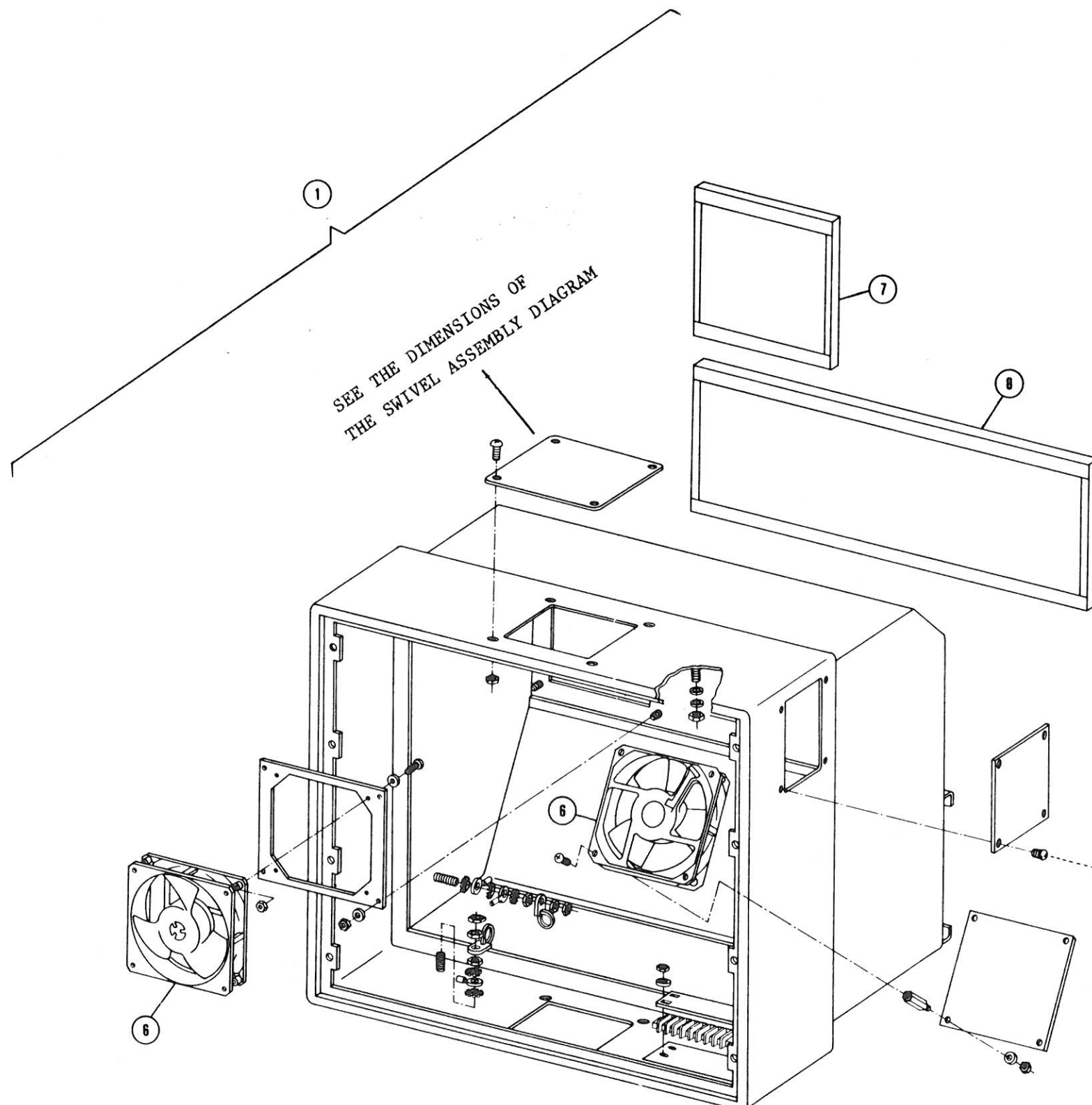

(Optional Equipment)

**Pendant Enclosure**

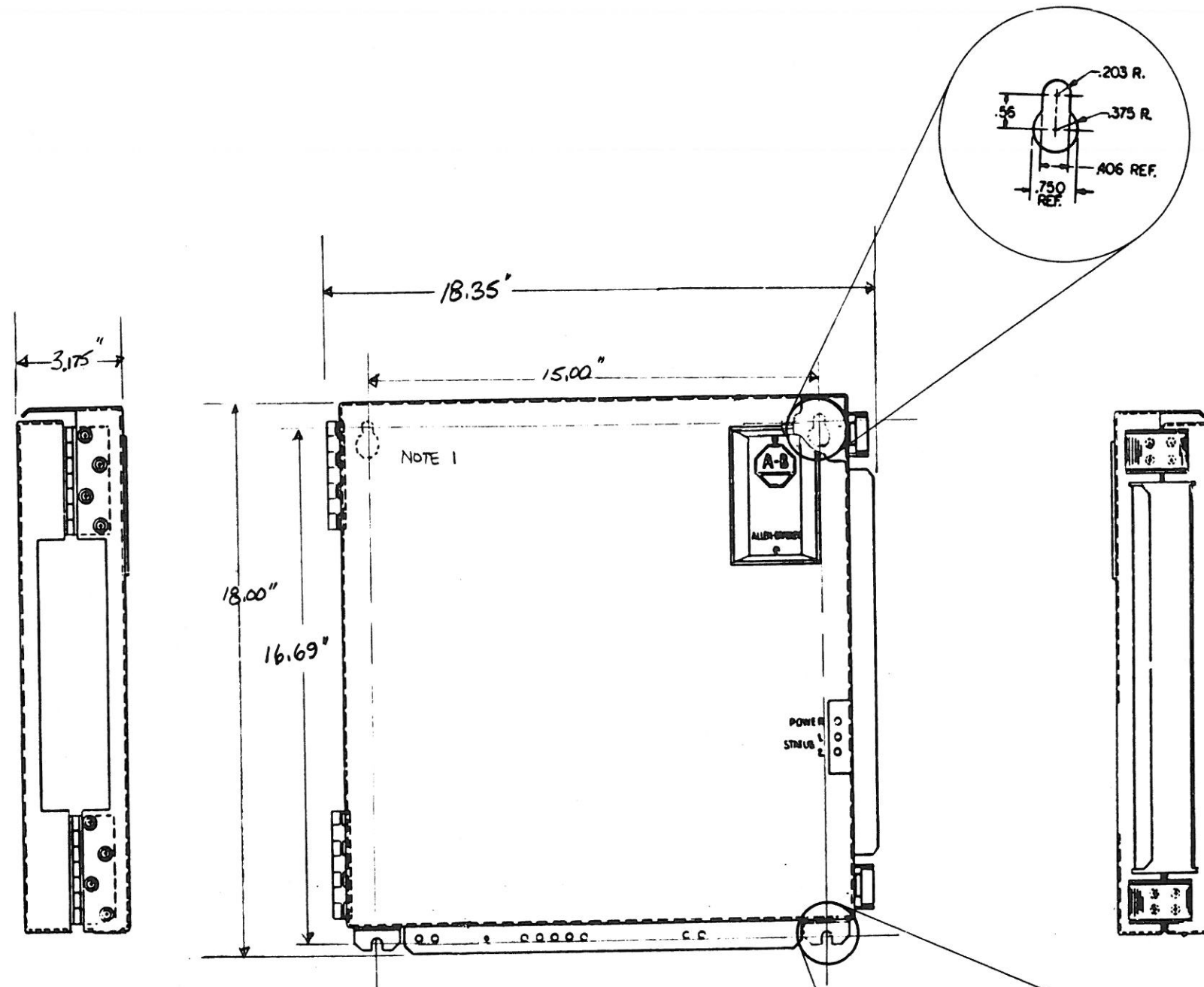

Front View

NOTE 1. PROCESSOR ENCLOSURE MUST BE OPENED TO ACCESS MOUNTING HOLE. ENCLOSURE CAN SWING OPEN 180 DEGREES.

DIMENSIONS OF PROCESSOR ENCLOSURE

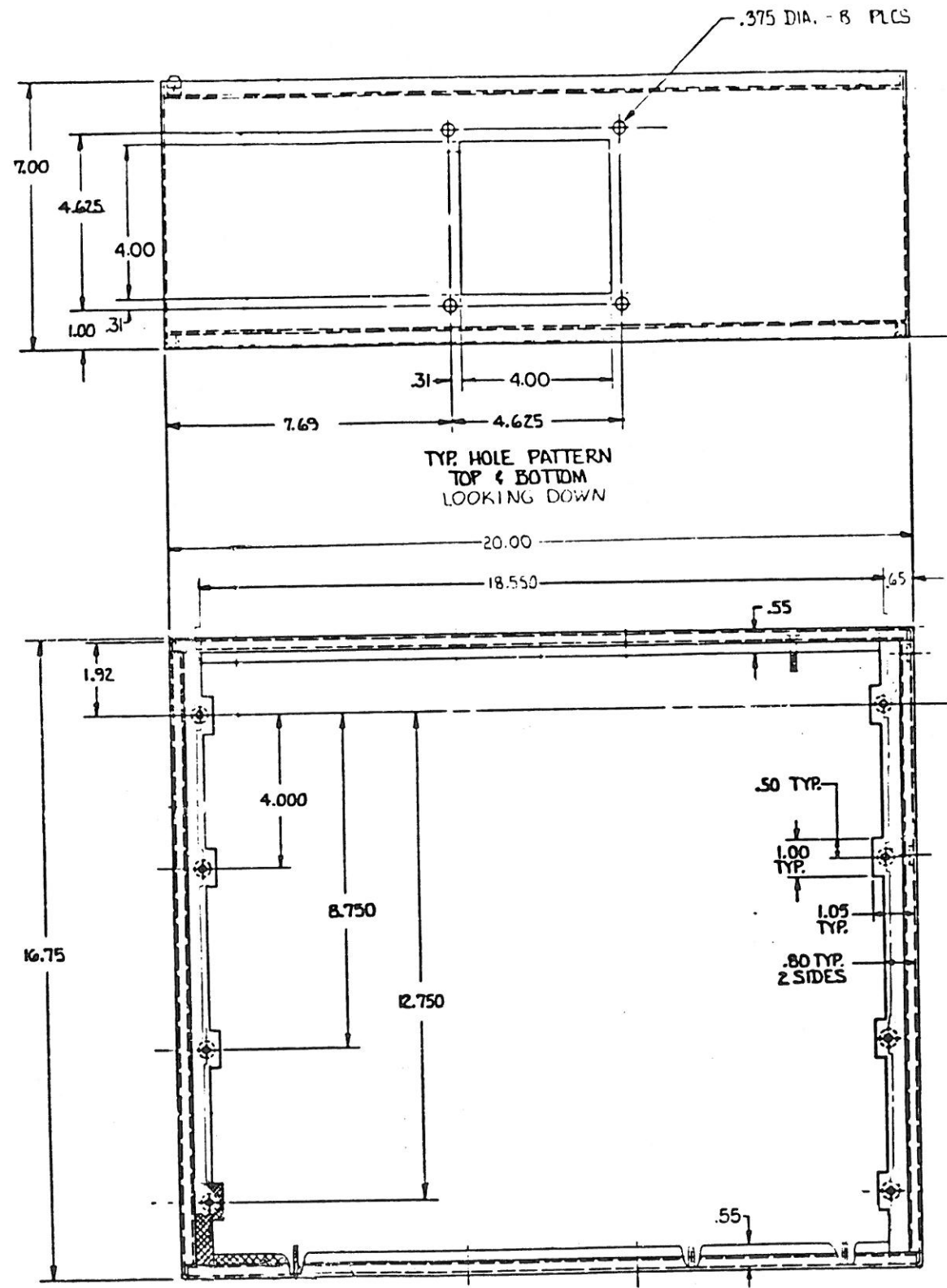

Front View

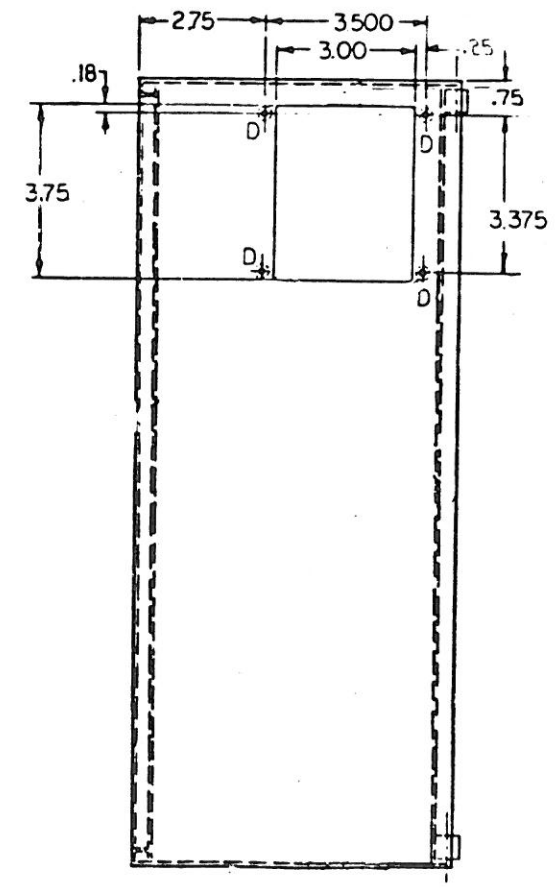

Right Hand View



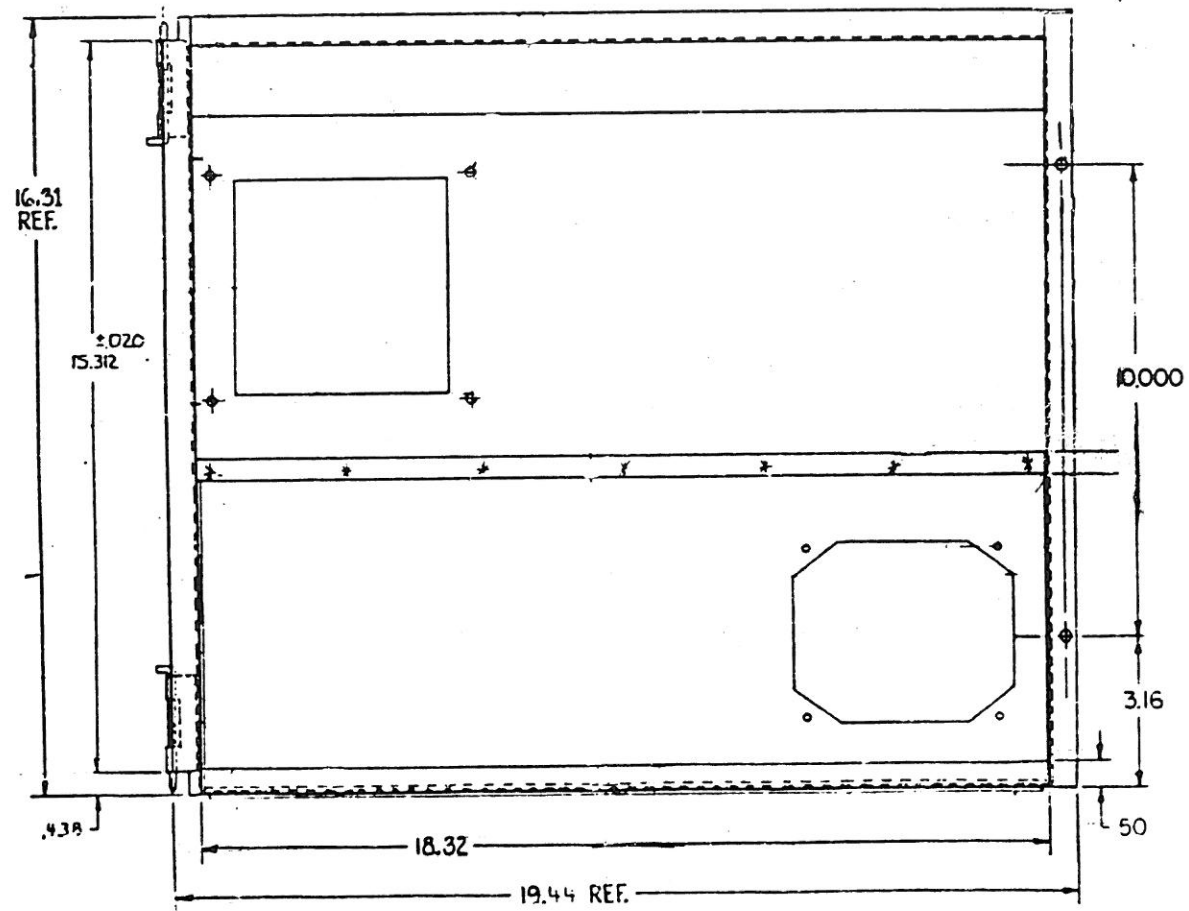

Rear View

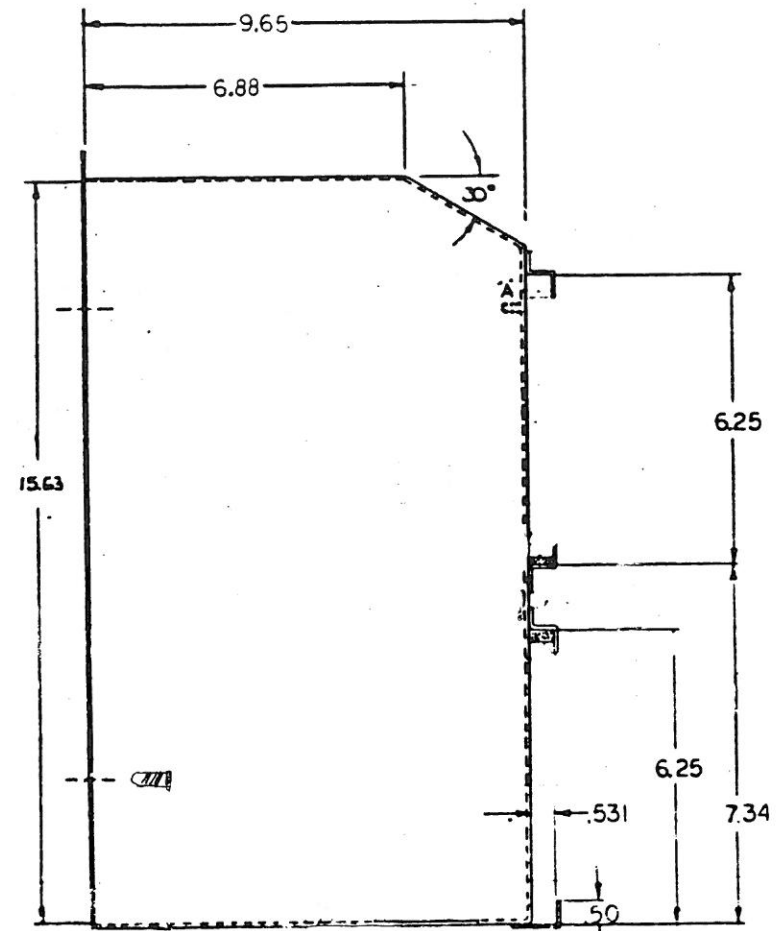

Right Hand View

DIMENSIONS OF HINGED PENDANT COVER

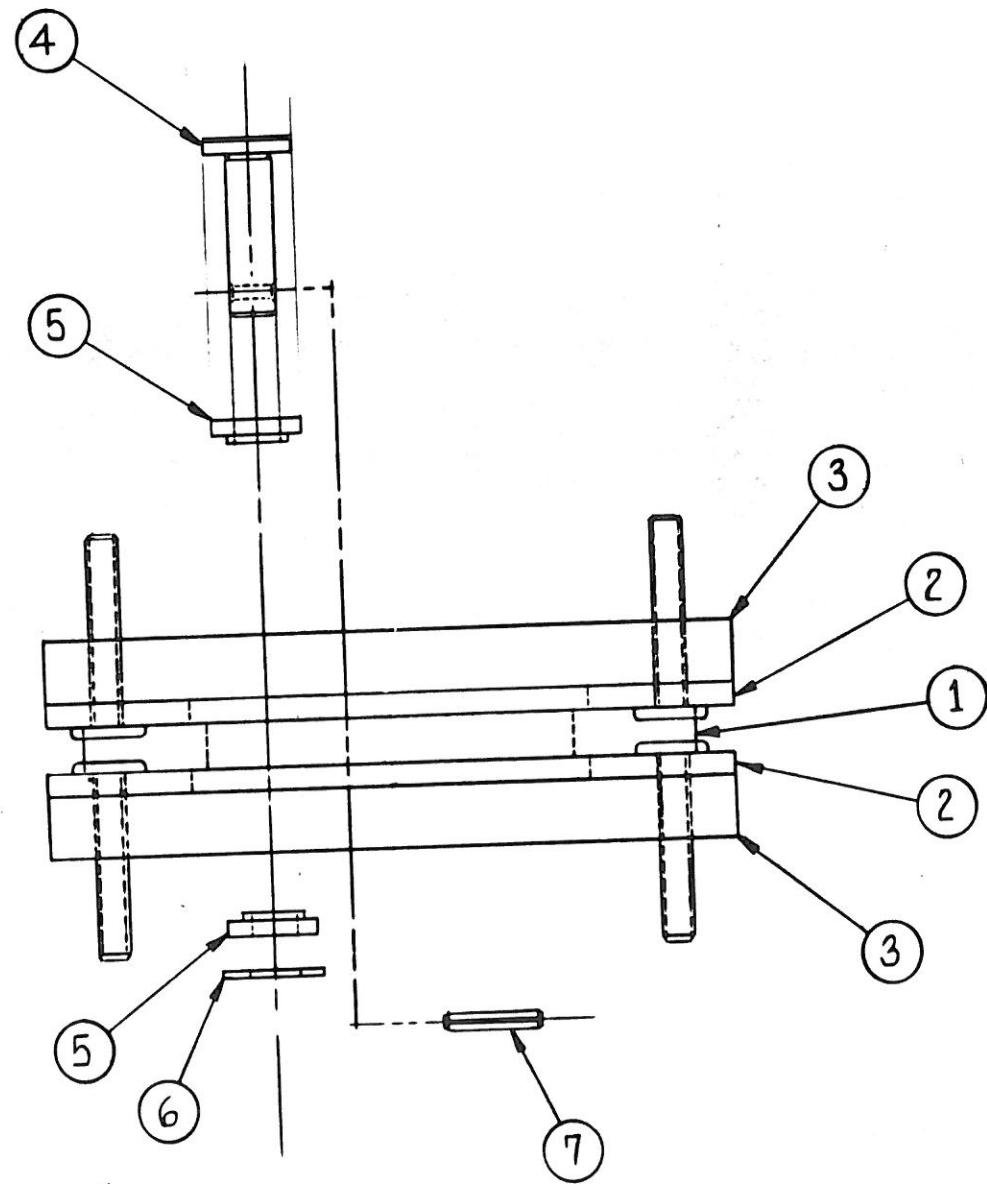

Swivel Assembly Parts List

ITEM	DESCRIPTION	QUANTITY
1	Swivel Bearing Ring	1
2	Swivel Mounting Plate	2
3	Swivel Gasket	2
4	Swivel Pin	3
5	Insulated Washer, Shoulder-.375	6
6	Flat 3/8 Washer	3
7	.75L Roll Pin, ss-.25D	3

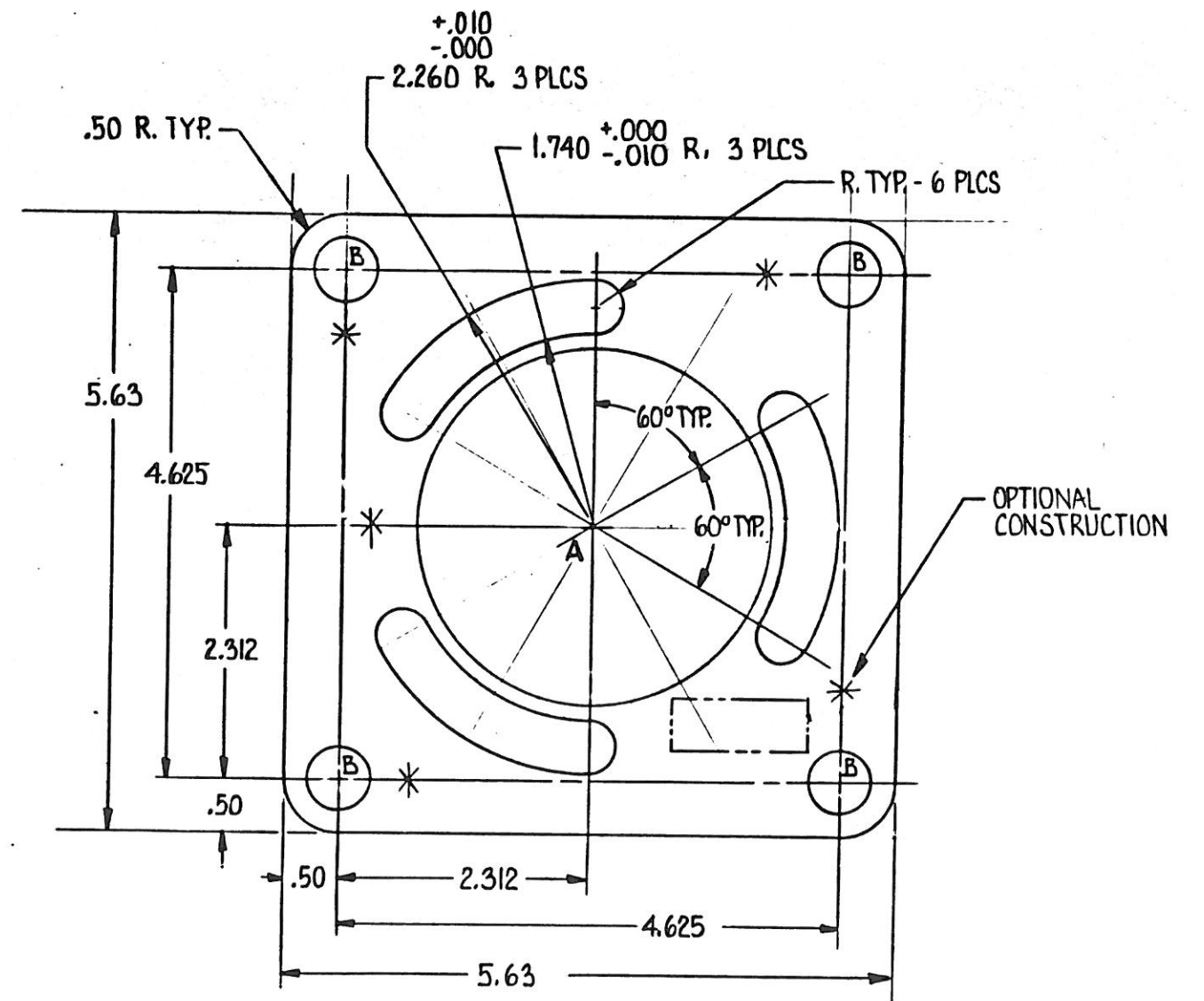

Catalog no. 8400-BSP

DIMENSIONS OF THE SWIVEL ASSEMBLY

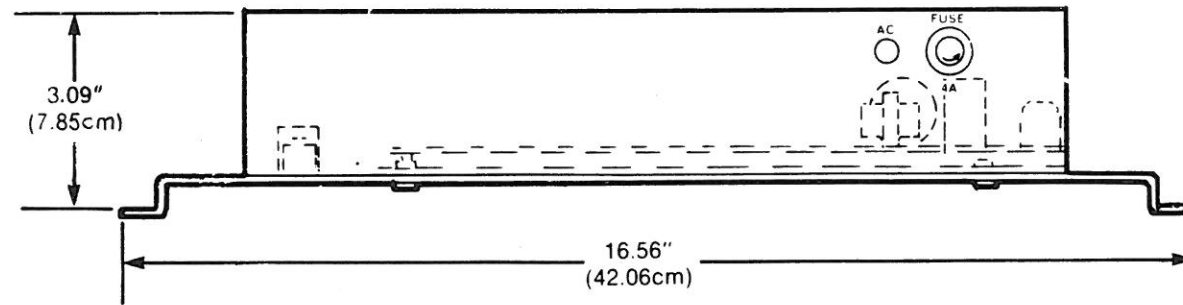
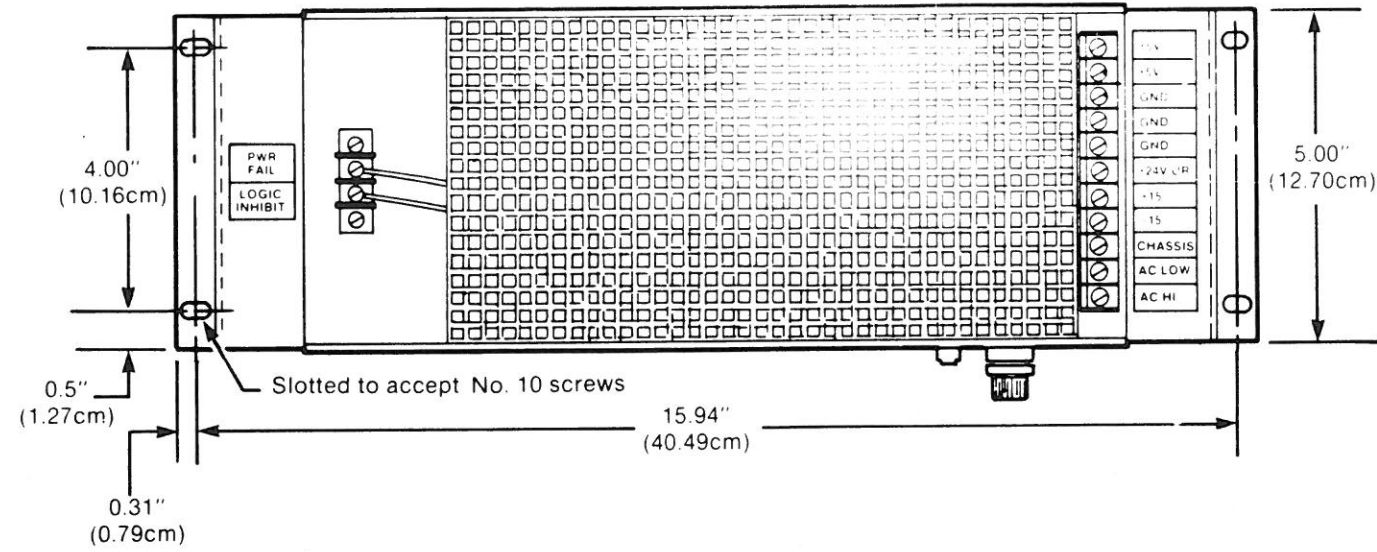

NOTE 1. THE POWER SUPPLY CAN ALSO BE MOUNTED WITH THE SUPPLIED MOUNTING BRACKETS. (SEE NEXT PAGE FOR DIMENSIONS OF POWER SUPPLY MOUNTING BRACKET.)

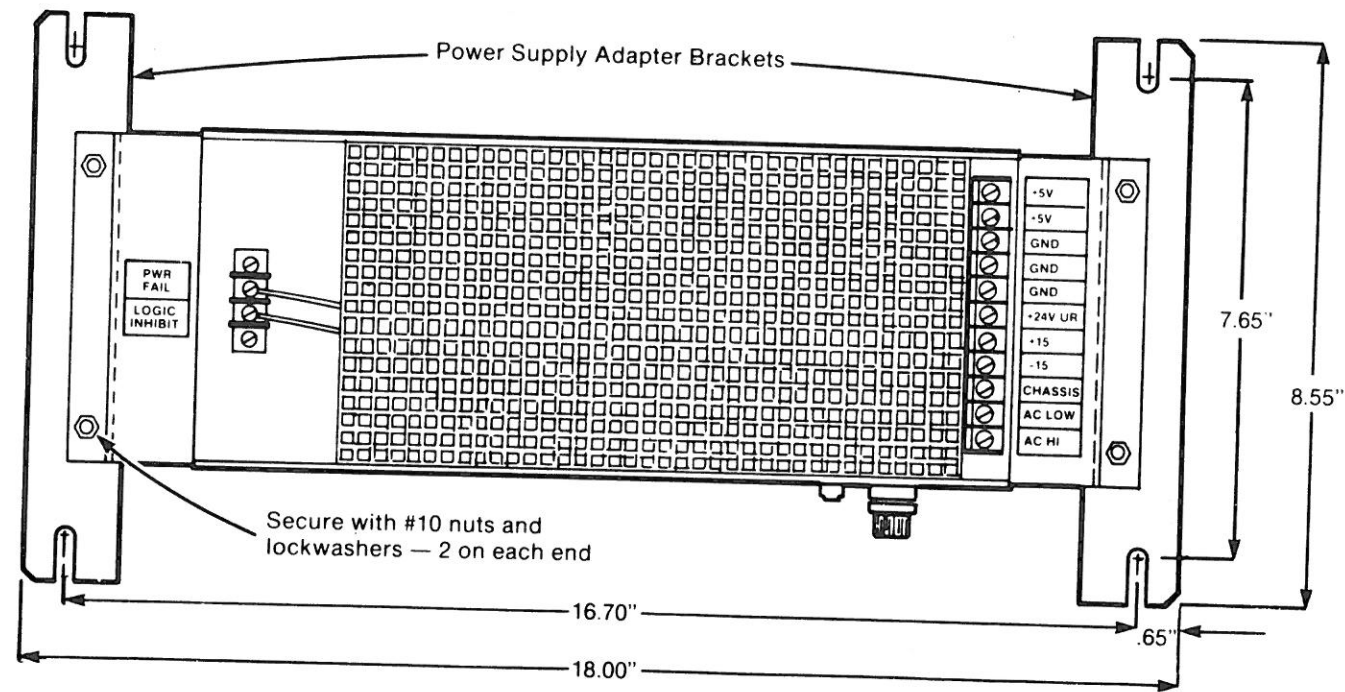

DIMENSIONS OF POWER SUPPLY MOUNTING BRACKET

General System  
Wiring

When wiring your system you have two options, you can purchase cables from A-B or make your own. We have kept the wire gauge sizes needed for the control's cables to a minimum. On some of the drawings, we've omitted minimum wire gauge sizes to reduce the number of cables.

Cables have a maximum working length specified on the drawings. Some A-B supplied cables are at a typical 22 feet working length, which is noted. These cables allow you to cut the cable to the proper length.

To install cables into the pluggable terminal block:

1. Strip 1/4 in. of insulation from the end of the cable.
2. Insert the cable into the pluggable terminal block.
3. Tighten the terminal block with a small flat-blade screwdriver.

Refer to the appropriate drawing when assembling cables as the drawing provides specific termination information.

Color Codes

Drawings that show color codes are intended to suggest the use of these colors as a way of following:

- o Allen-Bradley Workmanship Standards for color codes
- o The color code of the cables supplied by Allen-Bradley
- o The color code of wire most likely to be available from wire manufacturers

These suggested wire colors are only a guideline. Be sure any color code decisions you make comply with local wire coding laws and practices.

System Grounding

If a drawing specifies a chassis ground, be sure to use the specified gauge of wire in making the connection.

You will also need to install an uninterruptable earth ground connection to the system through a #8 AWG or larger wire. The earth ground should connect to a grounding bus of low impedance to which other ground wires in the system can be connected. Be sure to keep the ground wires leading to the ground bus as short as possible.

8400 AC Power  
Distribution

This diagram is an overview of the AC wiring requirements for the control. Wiring information for additional required devices such as cooling fans, air conditioners, coolant pumps, etc. is not provided.

To wire additional peripheral devices that require AC power, you must consider:

- o proper fuse ratings
- o transformer sizing
- o noise suppression devices based on total load requirements

You also need to supply an isolation stepdown transformer to provide 120V AC +/- 10% (single phase) to the 8400 PSB power supply and pendant electronics.

To select the transformer KVA rating, calculate the sum of the known power consumptions, using transformer efficiency, and derate if the transformer will be run at a higher temperature. Maximum power consumptions for the power supply and the monitor are shown in the AC Power Distribution Diagram.

Selecting the fuse ratings for primary and secondary fuses is system dependent, and you must properly determine these values. However, the 8400 PSB Power Supply and the color monitor are both protected internally by their own fuses. The 8400 PSB Power Supply has its own 4 amp fuse. If you need to replace this fuse, you can easily access it on the side of the power supply, and replace it only with a fuse of the same size and rating.

The color monitor is also internally protected by a 2 amp fuse. See The Color Monitor Connections And Location Diagram for replacement location.

You can best protect the control system from line noise and voltage fluctuations by using line noise suppression on the primary side of the transformer. You can also protect the monitor from any line noise by using a line filtering device on the transformer secondary. The minimum current rating should be 5 amps at 120 VAC.

You can minimize the noise paths and guarantee safe grounding by providing an uninterruptible earth ground connection to the system. You must connect it to a grounding bus of low impedance, and you connect other ground wires in the system to it. You define the location of the chassis ground point termination, while remembering to keep the lengths of all chassis and earth ground wires to a minimum.

Minimal AC wiring is required for the pendant, associated monitor, and peripheral panel because of the cabling provided for the pendant. For more details on the AC pendant wiring diagram, see the Pendant AC Terminal Block Connections Diagram.

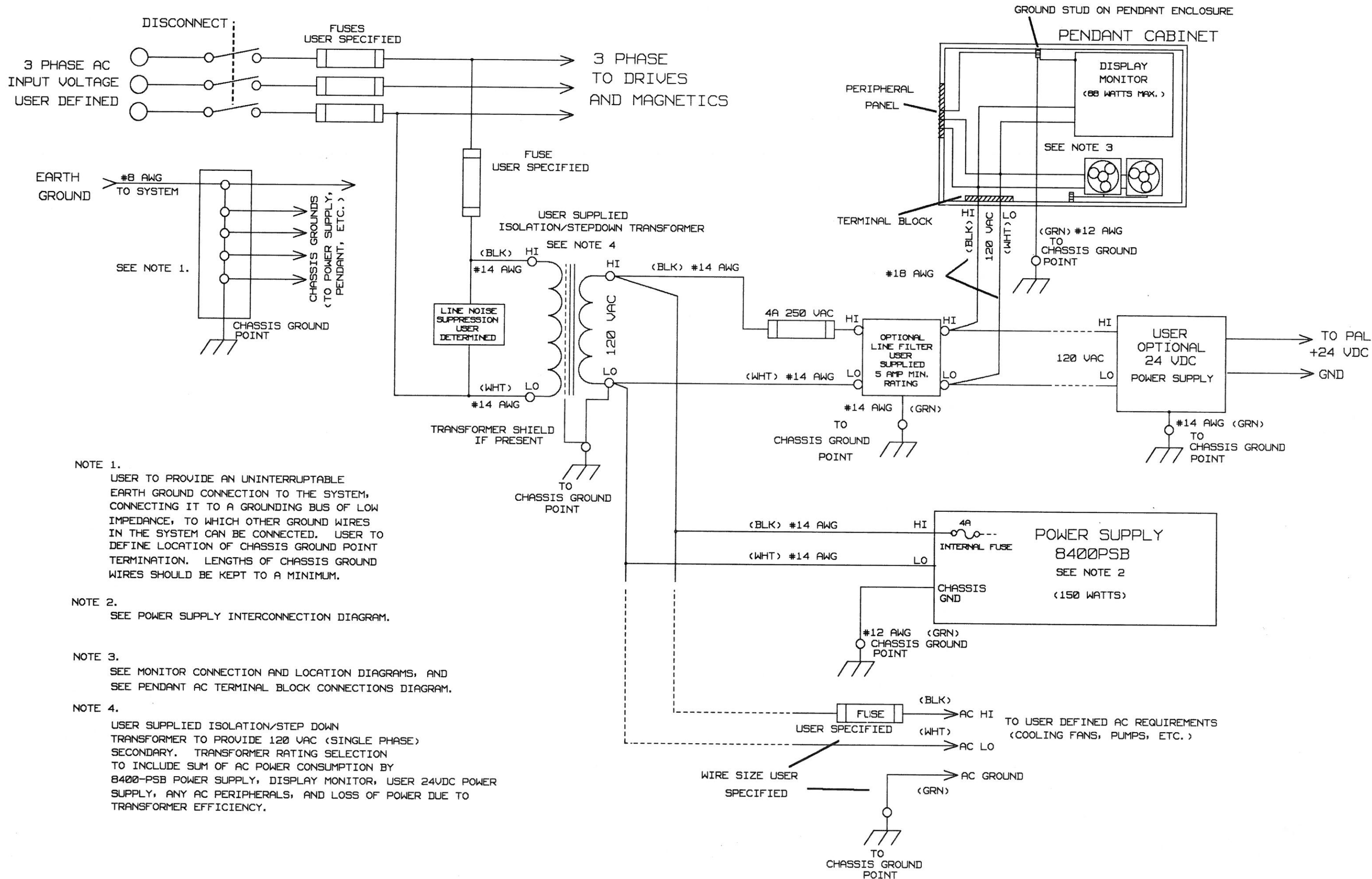

- NOTE 1.  
 USER TO PROVIDE AN UNINTERRUPTABLE EARTH GROUND CONNECTION TO THE SYSTEM, CONNECTING IT TO A GROUNDING BUS OF LOW IMPEDANCE, TO WHICH OTHER GROUND WIRES IN THE SYSTEM CAN BE CONNECTED. USER TO DEFINE LOCATION OF CHASSIS GROUND POINT TERMINATION. LENGTHS OF CHASSIS GROUND WIRES SHOULD BE KEPT TO A MINIMUM.
- NOTE 2.  
 SEE POWER SUPPLY INTERCONNECTION DIAGRAM.
- NOTE 3.  
 SEE MONITOR CONNECTION AND LOCATION DIAGRAMS, AND SEE PENDANT AC TERMINAL BLOCK CONNECTIONS DIAGRAM.
- NOTE 4.  
 USER SUPPLIED ISOLATION/STEP DOWN TRANSFORMER TO PROVIDE 120 VAC (SINGLE PHASE) SECONDARY. TRANSFORMER RATING SELECTION TO INCLUDE SUM OF AC POWER CONSUMPTION BY 8400-PSB POWER SUPPLY, DISPLAY MONITOR, USER 24VDC POWER SUPPLY, ANY AC PERIPHERALS, AND LOSS OF POWER DUE TO TRANSFORMER EFFICIENCY.

CPU/CRT Connector  
Location Diagram

This diagram provides you with the location and orientation of the control's connectors and user jumpers. This drawing also helps you to find details for the proper termination of each connector, by referring you to other drawings.

You can wire the connectors labeled plug-in terminal blocks to allow you to easily disconnect the wires if removal is necessary. To connect these wires:

1. Strip 1/4 inch of insulation off the terminating wire.
2. Twist the wires before inserting them into the terminals. This prevents loose individual wire strands from touching and shorting out the board.
3. Insert the wire into the terminal, and tighten the screw with a small screwdriver.

The CPU board has three user selected jumpers. By positioning a small shorting plug on the different pins, you will have different options concerning battery backup and non-volatile ram backup.

Jumper E3 selects whether the on board batteries will backup the ram memory during times of power down or power loss. To set the jumper for battery backup of ram memory, insert the jumper between pin 1 and pin 2. If the jumper is positioned between pin 2 and pin 3, loss of system power will result in the loss of ram memory content.

Jumpers E1 and E2 control which segment of ram space will be backed up by the battery. If your Eproms are installed in segment 1 or segment 2, then set your jumpers between pins 1 and 2. (For segment locations on the CPU board, see the CPU/CRT Board Layout Diagram.) If your ram chips are installed in segment 1 or segment 2, you set your jumpers E1 and E2 between pins 3 and 4. Normally, these jumpers are set at installation, and you shouldn't need to alter them.



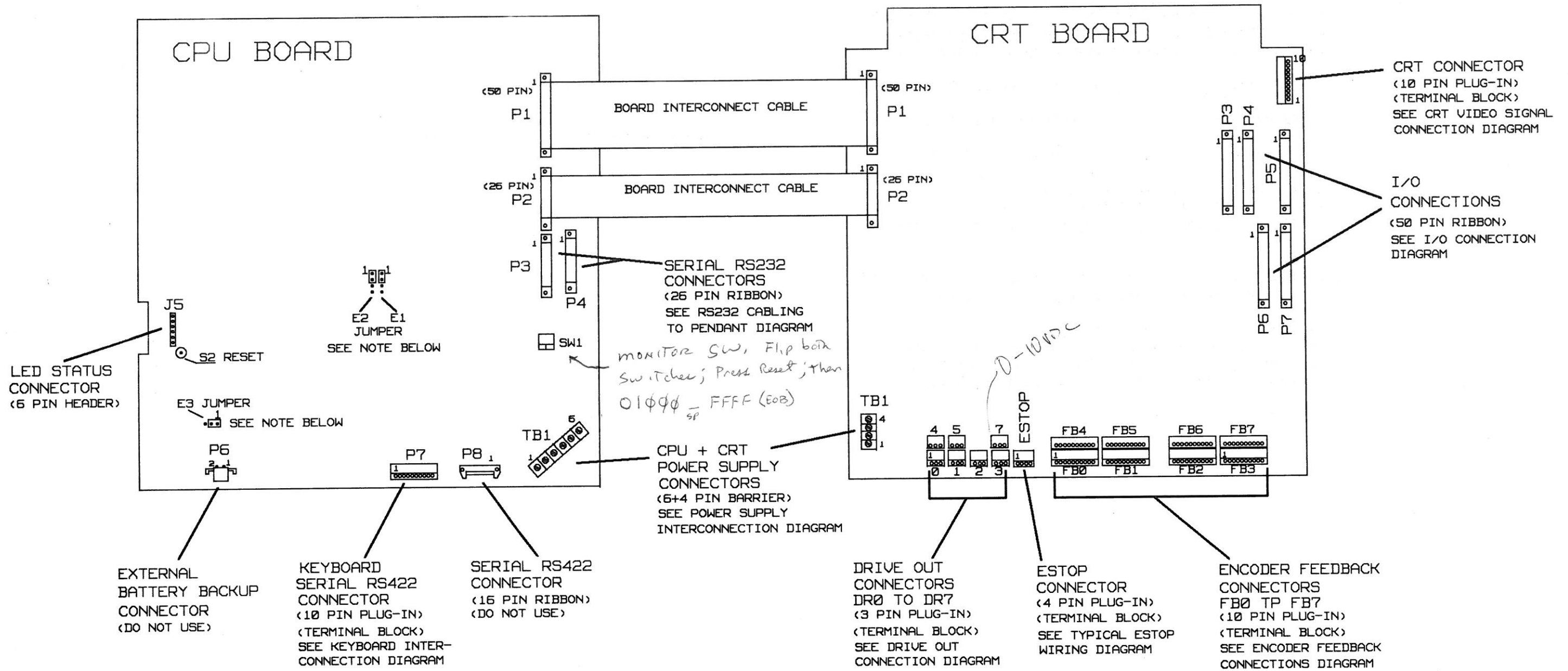

NOTE:

BATTERY BACK UP USER JUMPER

JUMPER	1-2	2-3
E3	BATTERY ON	BATTERY OFF

NON-VOL. RAM BACK UP

JUMPER	1-2	3-4
E1	5V	Vbattery Seg 1
E2	5V	Vbattery Seg 2

CPU/CRT CONNECTOR LOCATION DIAGRAM

CPU and CRT Module  
Layout

This sheet gives an overview of the sections that make up the CPU and CRT modules in the control package. The sheet also details certain components such as:

- o RAM segments
- o EPROM bank
- o color RAM
- o reset button S2
- o software switch SW1
- o jumpers E1, E2, E3

If you press the reset button, S2 on the CPU module, the system will re-initialize in a way that is similiar to a power up cycle, but without removing power.

Explanations of the jumpers E1, E2 and E3 can be found on the CPU and CRT Connector Location Diagram.

**CAUTION:** Do not attempt to adjust the 2 potentiometers in the control package. These are factory adjustments only. Random adjustment can adversely affect system performance and precision.

U 87 = 938-425-02	938-577-02	U 24 = 938-425-01	938-577-01
U 88 = 938-425-04	938-577-04	U 25 = 938-425-03	938-577-03
U 89 = 938-425-06	938-577-06	U 26 = 938-425-05	938-577-05
U 98 = 938-356-02	938-412-02	U 33 = NONE	938-577-07
U 107 = 938-356-01	938-412-01		
U 101 = 938-442-02	938-496-02		
U 110 = 938-442-01	938-496-01		
U 78 = NONE	938-577-08		

8420 BPEX  
HM 6264P-12 RAM  
1,2,5+6 Add  
3,4,7,8 Soldered in

8420 BPEFS  
JUST 3,4,7,8 Soldered in  
1,2,5+6 empty

8420 BPEX  
Extended memory  
Segment 1

U 91 = HM 6264 LP-15  
U 82  
U 73  
U 64  
U 55  
U 46  
U 37  
U 28

Segment 2

U 92  
U 83  
U 74  
U 65  
U 56  
U 47  
U 38  
U 29

### CPU BOARD

8420 BPEFS = 906 876-03

### CRT BOARD

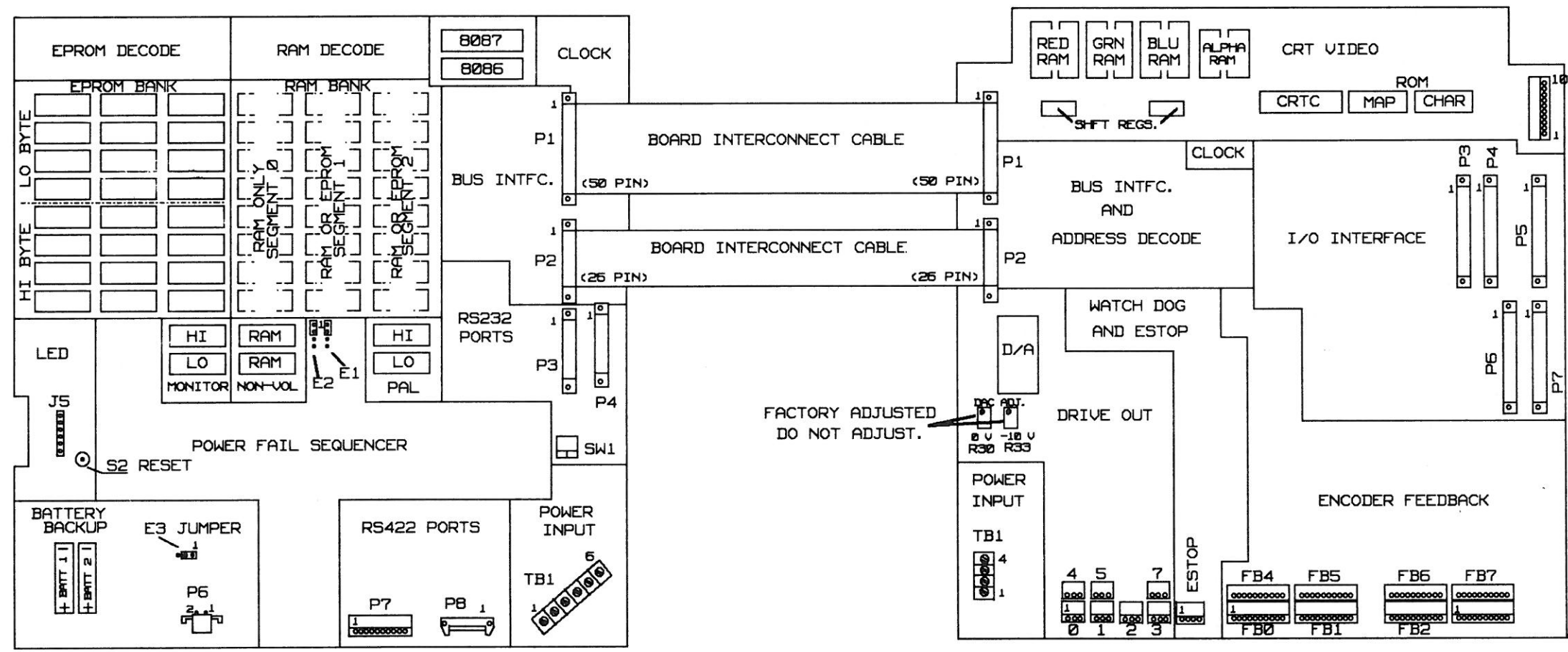

JUMPER	1-2	2-3
E3	BATTERY ON	BATTERY OFF

JUMPER	1-2	3-4
E1	5V	Vbattery Seg 1
E2	5V	Vbattery Seg 2

CPU/CRT BOARD LAYOUT DIAGRAM

Power Supply  
Interconnection  
Diagram

This drawing provides you with the information that you need to quickly and properly power from the 8400 PSB power supply to the control boards.

After wiring the AC power to the system, you must then wire DC power connection.

You must provide the lengths of wires that extend from the terminal block of the of the 8400-PSB power supply to the angled terminal block located on the CPU board. The wire specification table gives you the exact gauge and recommended colors. You can cut these wires to any length under six feet. You can easily meet this requirement by mounting the power supply as close as possible to the control boards. The supply should be mounted vertically to promote the best heat transfer from the supply.

Use the spade lugs provided with the power supply for each termination point shown in the drawing. The size of the spade lug should match the size of the wire you will crimp it to. To determine which spade lug to use, see the terminal lug table. You can identify the different types of spade lugs by their color coded sleeves. You also need a lug crimping tool to firmly secure the wire within the lug. (Any extra lugs provided with the power supply, can be used or discarded.)

The interconnecting wires between the CPU (Tb1) and the CRT (Tb1) have been precut, lugged and installed. (The ground wire between the two halves of the enclosure is also provided.) To merge two wires on the same terminal point, you must invert one of the spade lugs on the end of the connecting wires. By inverting the bottom lug, you can stack two spade lugs per terminal point. Insert the lugs under the terminal block pressure plates before tightening. Check each terminal point to be sure that it is tightened properly.

The ground wires are meant to be kept to a minimum length and tied to a chassis ground point. You should keep the chassis ground point or ground bus point as close to the power supply as possible. The maximum length of the chassis ground wire to chassis ground point is one foot of #12 AWG stranded wire. (All wire gauges given are for the use of stranded wire only.)

You must also provide an uninterruptible earth ground connection to the system, connecting it to a low impedance grounding bus. The other grounding wires in the system can be terminated to a low impedance grounding bus.

This diagram specifies stranded wires, except for the power fail cable which requires a #16 gauge shielded cable.

To terminate the cable shield drain wire:

1. Insert the drain wire into a lug under the barrier strip mounting stud.
2. Cut the other end of the shield wire back, and cover the end with heat shrink tubing.
3. Leave the shield unterminated at the CPU board.

Power Supply Loading

Power supply (cat. no. 8400 PSB) is the main power supply of the system. The supply provides power to: PAL, the CPU board, the CRT board, and the I/O boards. The CPU and CRT boards use both the +5V DC and +15V DC outputs.

The +15V DC outputs are for the CPU and CRT boards exclusively. It is not to be used for any other application.

The +5V DC output provides power not only to the CPU and CRT boards but also to the I/O board. Allocated I/O board power is 1.4 Amps (120 I/O points at 12 mA per point).

An additional output is provided to PAL at +24V DC +/- 5% with a maximum current drain of 1.5 Amps. This output requires a minimum current drain of .25 Amps to achieve regulation at 24V. You will have to calculate the minimum operating current of the devices you will power from this output. Add a resistive load to guarantee regulation if necessary.

If you use the +24V supply to power the front panel lamps only (no other PAL devices connected to the +24V output), refer to the RS232 Cabling to Pendant Diagram, as you will need to add a resistive load in parallel to guarantee regulation. In this case, a 82 ohm 10 watt resistor will guarantee regulation. You are responsible for selecting this resistor.

Important: If you do not load the +24V supply, its' voltage can rise to +35V DC.

The supply's maximum output power is 150 watts at 50 degrees C. Derate the supply linearly to 50% at 70 degrees C. Refer to publication 8400-4.5.1 for additional information on the 8400 PSB supply.

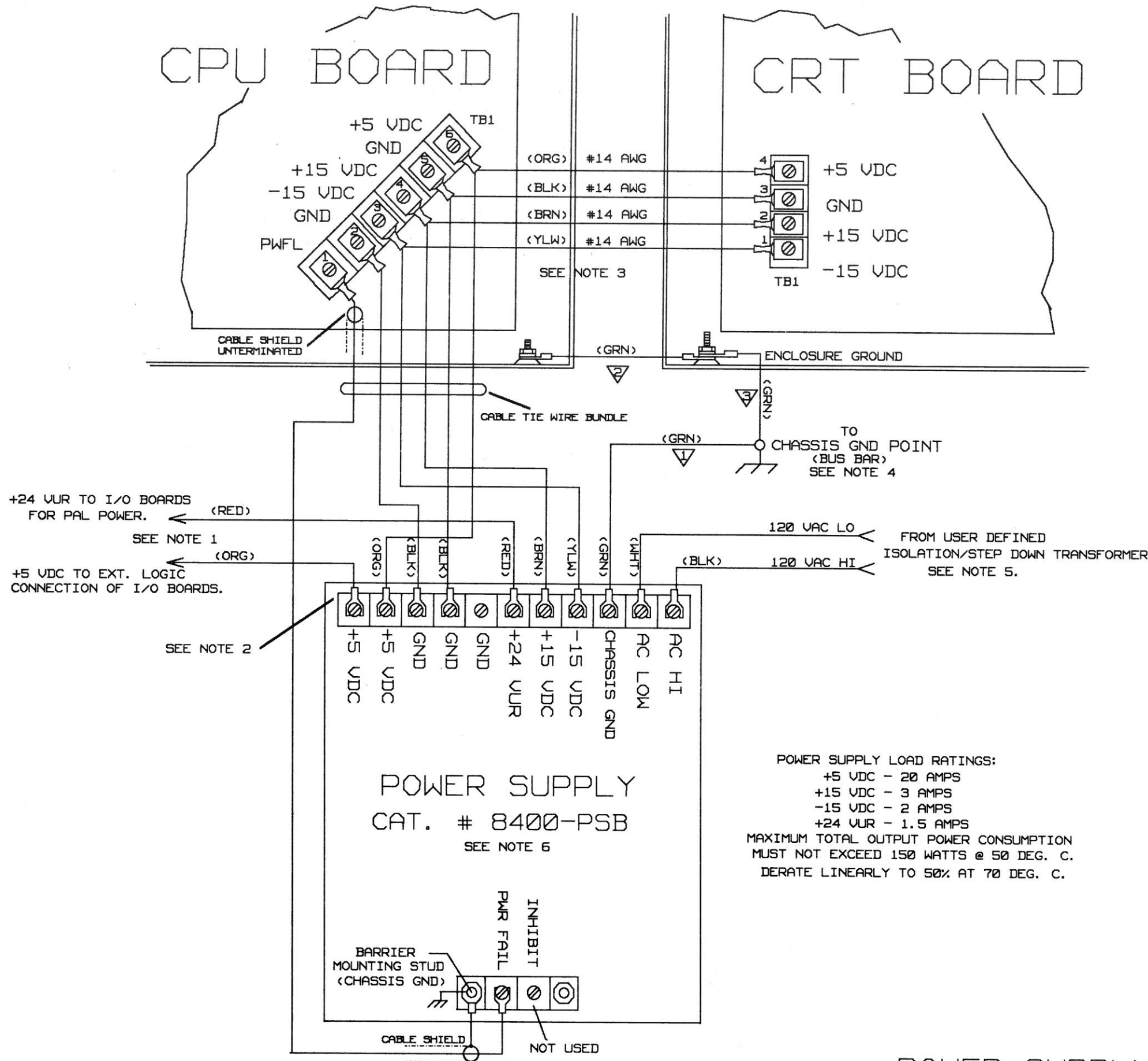

WIRE SPECIFICATION TABLE			
WIRE	COLOR CODE	AWG	MAXIMUM LENGTH
+5 +15 -15 GND	ORANGE BROWN YELLOW BLACK	#12 #12 #12 #12	POWER SUPPLY TO CPU BOARD 6 FT.   6 FT.
AC LOW AC HI	WHITE BLACK	#14 #14	USER DEFINED USER DEFINED
PWR FAIL	GREY CABLE	#16	6 FT.
CHASSIS GND 1	GREEN	#12	1 FT.
2	GREEN	#12	0.5 FT.
3 (SEE NOTE 4)	GREEN	#10 #8	IF < 2 FT. IF < 5 FT.
I/O LOGIC	ORANGE	#12	SEE NOTE 1
+24 VDC	RED	#14	-

NOTE 1. SEE I/O BOARD LOGIC SUPPLY WIRING DIAGRAM.

NOTE 2. USE SPADE TERMINAL LUGS FOR POWER SUPPLY CONNECTIONS. MAXIMUM OF TWO STACKED LUGS PER SINGLE TERMINAL POINT. SPADE LUGS ARE PROVIDED WITH CAT. # 8400-PSB.

TERMINAL LUG TABLE		
WIRE/LUG SIZE	SLEEVE COLOR	STUD SIZE
#10-#12	YELLOW	#8
#14-#16	BLUE	#8
#16-#22	RED	#8

(USE RING LUG TERMINALS FOR ENCLOSURE GROUNDS)

NOTE 3. INTERCONNECTING WIRES BETWEEN CPU AND CRT BOARDS ARE PROVIDED WITH SPADE LUG TERMINATIONS. INVERT THE BOTTOM LUG WHEN STACKING TWO LUGS PER TERMINAL. INSERT LUG UNDER TERMINAL BLOCK PRESSURE PLATE BEFORE TIGHTENING.

NOTE 4. USER TO PROVIDE AN UNINTERRUPTABLE EARTH GROUND CONNECTION TO THE SYSTEM, CONNECTING IT TO A LOW IMPEDANCE GROUNDING BUS, TO WHICH OTHER GROUNDING WIRES IN THE SYSTEM CAN BE TERMINATED.

NOTE 5. SEE AC POWER DISTRIBUTION DIAGRAM.

NOTE 6. FOR BEST HEAT TRANSFER, MOUNT POWER SUPPLY VERTICALLY.

POWER SUPPLY INTERCONNECTION DIAGRAM

## CRT Video Signal Connection

The system will have either a:

- o monochrome monitor (cat. no. 8000-XBVD)
- o color monitor (cat. no. 8000-XCVD)

This diagram gives the connections for both types of monitors. A dotted line separates the two configurations. Use the one that corresponds with your system.

### Monochrome Monitor

A monochrome monitor comes with a 22 foot coaxial cable (cat. no. 8400 - CBBW) that has a pre-installed female BNC connector. See the Video Signal Cable for the Monochrome CRT. You can cut this cable for the length you need between the monitor and the CRT module in the control package.

1. Connect the BNC end of the cable to the male BNC connector, marked IN, on the rear of the monitor. This is a twist on connection. The other BNC connector on the rear of the monitor, marked OUT, has no connection.
2. Next to the BNC connectors on the monitor, you will see a small switch. Verify that it is in the 75 ohm position.
3. Cut the coaxial cable to the length you need.
4. Strip back enough of the cable to solder two #20 wires to it. The two wires, black and white, are included with the cable.
5. Solder the black wire to the tinned coaxial braid.
6. Solder the white wire to the center conductor of the cable.
7. Cover these connections with enough heat shrink tubing, also provided, to prevent the connections from shorting together.
8. Strip back 1/4 in. of insulation from the black and white wires.
9. Insert the black wire in position 9 of the CRT connector on CRT module (refer to the CPU/CRT Connector Location Diagram, if necessary). The white wire goes to position 10. The pin locations are found on this diagram.
10. Tighten the CRT connector on the black and white wires.

Other than the AC power connections covered on the Color Monitor Connections and Location Diagram, these are all the video connections required by the monochrome monitor.

### Color Monitor

A Color monitor system comes with a 22 foot coaxial cable that has a 6 prong video connector on one end. You can cut this cable for the length between the color monitor and the CRT module in the control package.

1. Connect the 6 prong connector to the connector on the chassis of the color CRT.
2. Connect a ground wire to the chassis of the color monitor.
3. Prepare the end of the cable that connects to the CRT module by stripping back about 2.5 in. of insulation. This will expose 8 color-coded wires.
4. Strip 1/4 in. of insulation from each wire.
5. Take the #20 black wire, provided, and solder it to the cable shield. Cover the solder joint with heat shrink tubing.
6. Strip the end of the black wire 1/4 in.
7. Following the color codes of the wires, insert each into the plug-in terminal block and tighten each screw to secure the wire.

This completes video wiring for the color monitor. Refer to the Color Monitor Connections and Location Diagram for AC power connections for the color monitor.

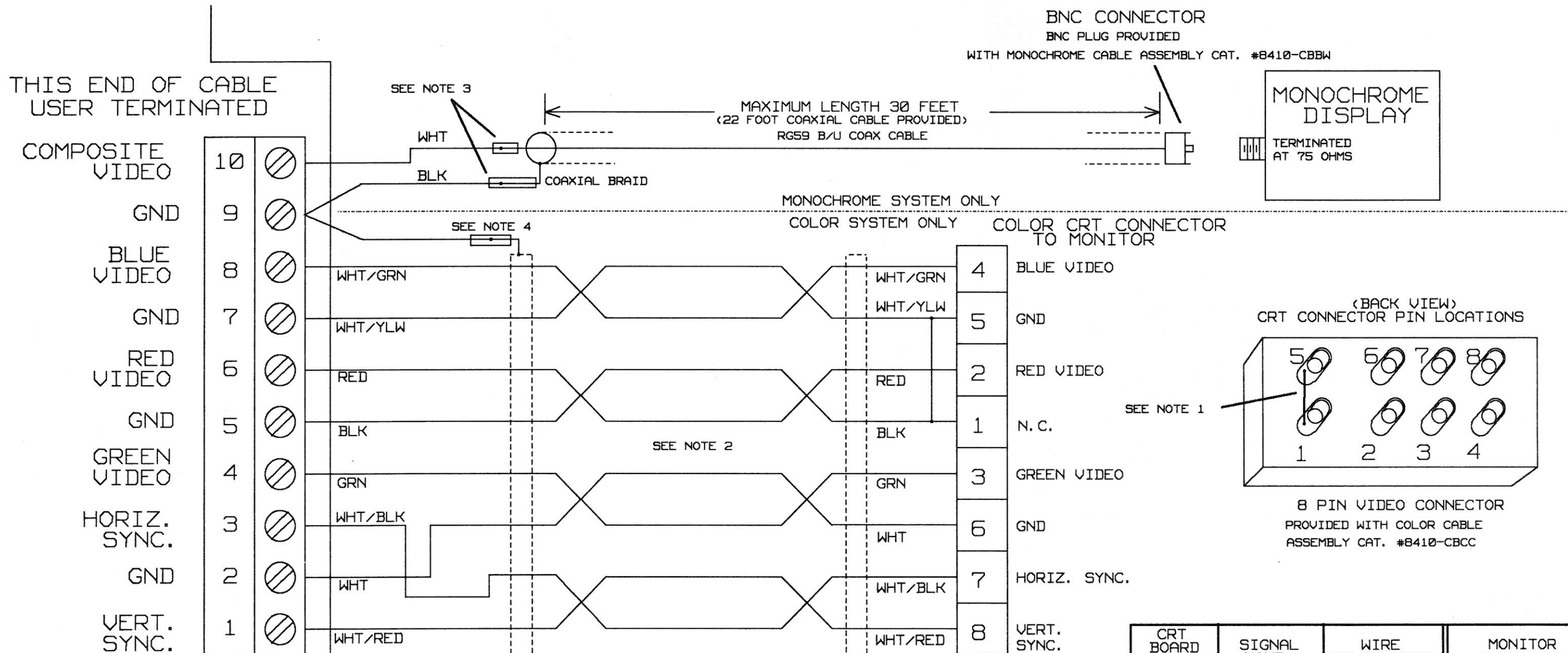

CRT CONNECTOR ON CRT BOARD

SEE CPU/CRT CONNECTOR LOCATION DIAGRAM.

NOTE 1. A #20 WIRE IS SOLDERED BETWEEN PIN 1 AND PIN 5 OF THE VIDEO CONNECTOR. THIS WIRE COMES PRE-SOLDERED AS A PART OF COLOR CABLE ASSEMBLY CAT. #8410-CBCC, AS SUPPLIED BY ALLEN BRADLEY.

NOTE 2. A 22 FOOT, 4 INDIV. TWISTED PAIR, #20 AWG SHIELDED CABLE IS PROVIDED. THIS LENGTH CAN BE CUT TO THE USER REQUIREMENTS.

NOTE 3. SOLDER A SEPERATE #20 AWG WIRE TO THE COAXIAL BRAID AND TO THE COAXIAL CENTER CONDUCTOR, BEFORE TERMINATING THE CABLE TO THE CRT BOARD. COVER EXPOSED BRAID AND SOLDER CONNECTIONS WITH HEAT SHRINK TUBING.

NOTE 4. TWIST ALL DRAIN WIRES TOGETHER AND SOLDER A #20 AWG WIRE TO THE DRAIN WIRES. COVER EXPOSED DRAIN WIRES AND SOLDER CONNECTION WITH HEAT SHRINK TUBING.

	CRT BOARD PIN#	SIGNAL NAME	WIRE COLOR CODE	MONITOR CONNECTOR
B/W	10	COMP. VIDEO	-	BNC CENTER COND.
	9	GND	-	SHIELD
COLOR SYSTEM	8	BLUE VIDEO	GRN/WHT	PIN 4
	7	GND	YLW/WHT	PIN 5
	6	RED VIDEO	RED	PIN 2
	5	GND	BLACK	PIN 1
	4	GREEN VIDEO	GREEN	PIN 3
	3	HORIZ. SYNC.	BLK/WHT	PIN 7
	2	GND	WHITE	PIN 6
	1	VERT. SYNC.	RED/WHT	PIN 8

RS232 Cabling to  
Pendant

This drawing describes the cabling necessary to connect the RS232 ports on the CPU board to the peripheral panel in the pendant.

This drawing also shows the pin location of connectors P3 and P4 on the CRT board. P3 and P4 are 26-pin male header connectors. Refer to the CPU/CRT Connector Location Diagram for the location of the connectors on the board.

Connector P3 is used for the communication cable between the control and the optional Kaypro II personal computer (cat. no. 8400XK).

Connector P4 is typically used for the other peripheral devices: the Decitek Reader (cat. no. 8000 XRDR), the 1770-SB Cartridge Recorder, or Serial Audio Cassette (part no. 21210006).

Connector P4 also provides +/- 13.6V DC to power the Serial Audio Cassette. Two pico fuses limit the current draw to 1/16 Amp on each 13.6V DC line. The pico fuses are shown on the drawing.

A ready made RS232 cable is available from Allen-Bradley (cat.no. 8410 - SCBL). It is 22 feet in length and has the proper connector attached to each end. See the Serial Communications Cable Diagram. Any excess cable length should be cable tied as shown in the drawing.



**P3 ON CPU BOARD**  
(26 PIN HEADER)

CHASSIS GND	1
SDA	3
TSE DCEA	4
RDA	5
RSA	7
CSA	9
DMA	11
SIGNAL GND	13
TRA	14
RRA	15
N. C.	21
TSE DTEA	22
N. C.	24

**DEDICATED KAYPRO PORT**

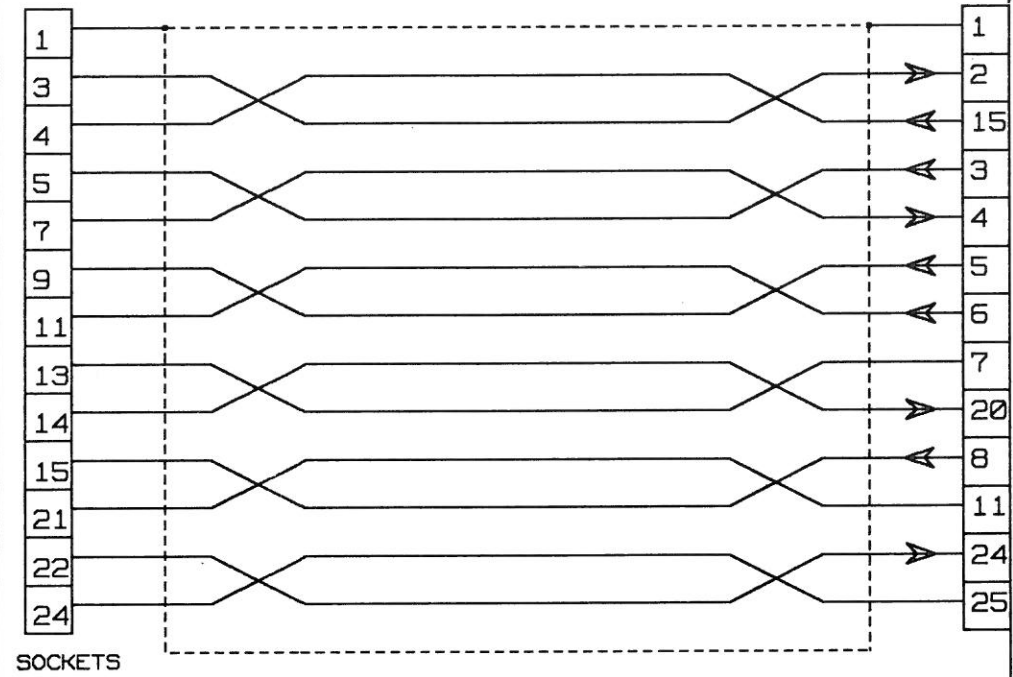

← MAXIMUM LENGTH 30 FEET  
22 FEET PROVIDED WITH CAT. #B410-SCBL →

RS232 DESIGNATIONS

1	PROTECTIVE GROUND
2	TRANSMIT DATA
15	TRANS. SIGNAL ELEMENT TIMING
3	RECEIVED DATA
4	REQUEST TO SEND
5	CLEAR TO SEND
6	DATA SET READY
7	SIGNAL GROUND
20	DATA TERMINAL READY
8	RECV. LINE SIGNAL DETECT
11	N. C.
24	TRANS. SIGNAL ELEMENT TIMING
25	N. C.

CONNECTOR MOUNTED ON PENDANT PERIPHERAL PANEL. SEE PENDANT ENCLOSURE DRAWING.

**CPU BOARD**

SEE PAGE 2 FOR CONNECTOR LOCATIONS.

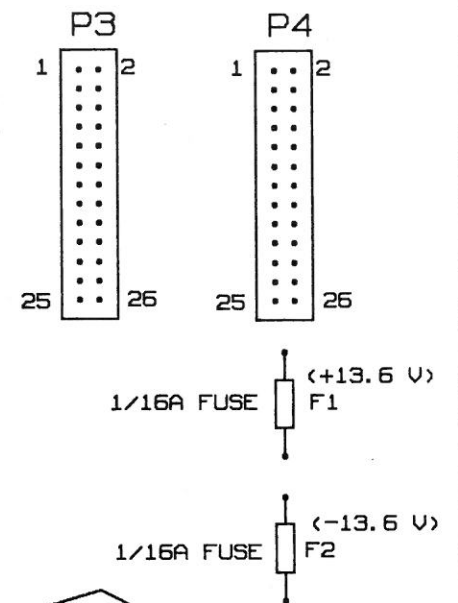

**P4 ON CPU BOARD**  
(26 PIN HEADER)

CHASSIS GND	1
SDB	3
TSE DCEB	4
RDB	5
RSB	7
CSB	9
DMB	11
SIGNAL GND	13
TRB	14
RRB	15
+13.6 VDC	21
TSE DTEB	22
-13.6 VDC	24

**UNIVERSAL RS232 PORT**

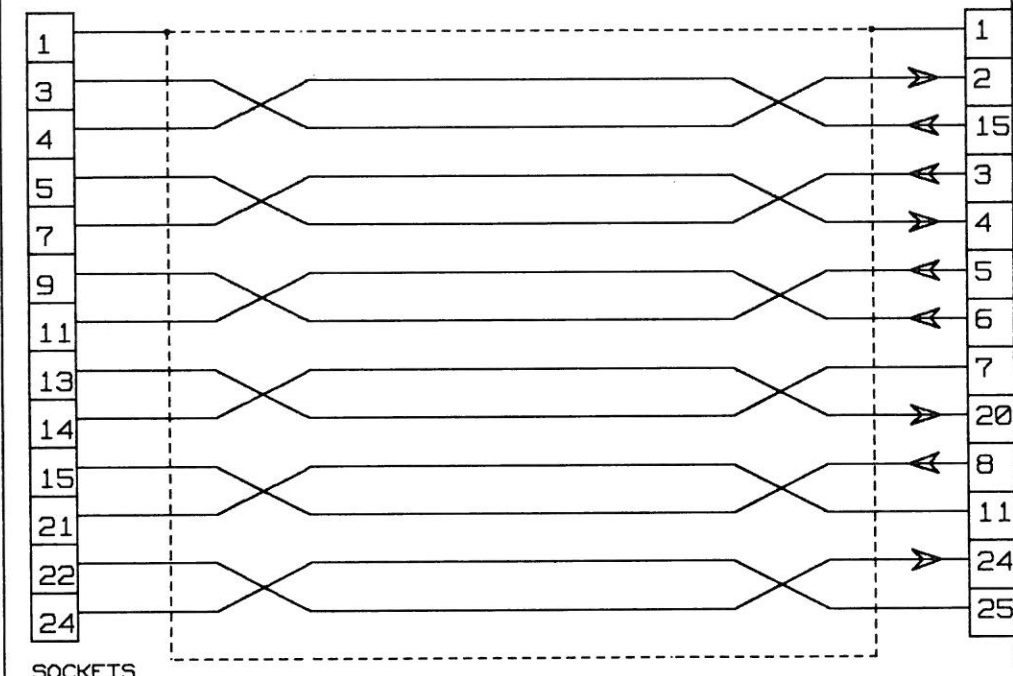

← MAXIMUM LENGTH 30 FEET  
22 FEET PROVIDED WITH CAT. #B410-SCBL →

RS232 DESIGNATIONS

1	PROTECTIVE GROUND
2	TRANSMIT DATA
15	TRANS. SIGNAL ELEMENT TIMING
3	RECEIVED DATA
4	REQUEST TO SEND
5	CLEAR TO SEND
6	DATA SET READY
7	SIGNAL GROUND
20	DATA TERMINAL READY
8	RECV. LINE SIGNAL DETECT
11	+13.6 VDC (45 MA. MAX)
24	TRANS. SIGNAL ELEMENT TIMING
25	-13.6 VDC (45 MA. MAX)

CONNECTOR MOUNTED ON PENDANT PERIPHERAL PANEL. SEE PENDANT ENCLOSURE DRAWING.

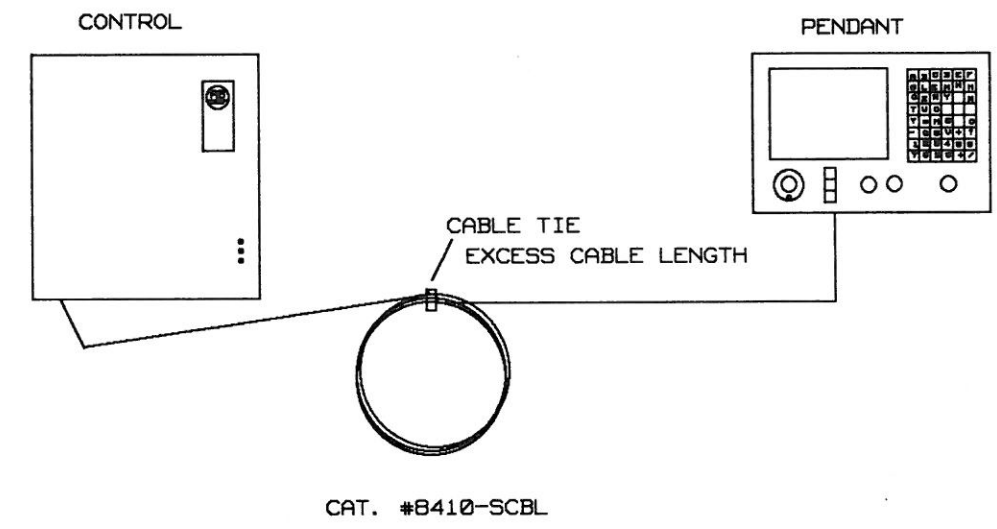

**RS232 CABLING TO PENDANT**

## Handwheel Wiring

If your system has the Handwheel Option (cat. no. 8000 - XHP) you need to install a cable from connector FB6 on the CRT board to the 9 pin connector on the handwheel.

Allen-Bradley provides a ready made handwheel cable (cat. no. 8410 - CBHW) or you can make your own.

The A-B cable comes with a 9 pin connector at one end. The cable is 22 feet which has 3 individually shielded twisted pairs of #20 AWG wire. You can cut the cable to length once the pendant handwheel has been installed.

If you make your own cable, refer to the wire specifications on the Handwheel Connections Diagram.

1. For the FB6 connection, strip 1/4 in. of insulation from the wire, twist the strands together before inserting it into the connector.
2. Twist the drain wires of the cable together.
3. To prevent the drain wires from shorting out other connections, solder a short piece of a similar gauge insulated wire to the drain wire.
4. Cover the connection with heat shrink tubing to prevent shorting.
5. Strip a 1/4 in. of insulation from the wire, twist the strands together before inserting it into the connector.

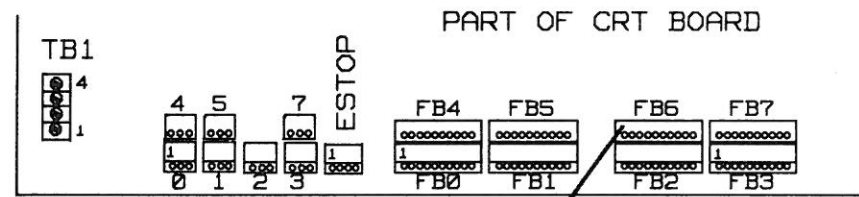

LOCATION OF HANDWHEEL CONNECTOR (FB6) ON CRT BOARD

CONNECTOR LABEL	PIN ASSIGNMENT									
	1	2	3	4	5	6	7	8	9	10
FB6	CHANNEL A HI	CHANNEL A LO	SHIELD	CHANNEL B HI	CHANNEL B LO	+5 VDC	GND	SHIELD	DO NOT USE	DO NOT USE

ON CRT BOARD

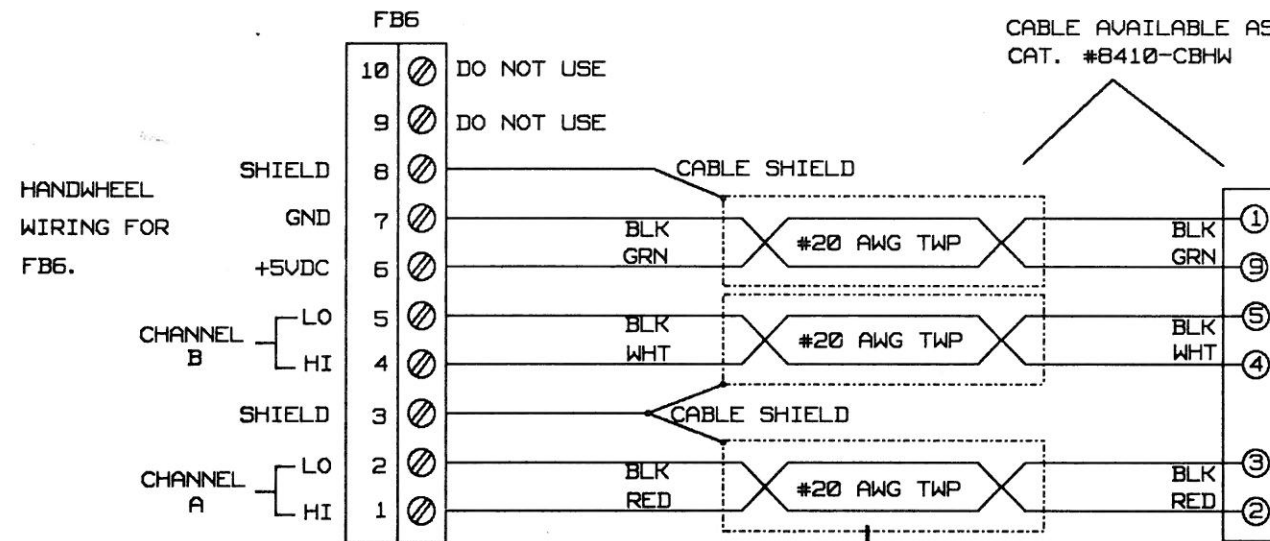

SEE PENDANT LOCATION DIAGRAM FOR HANDWHEEL LOCATION.

9 PIN D SERIES CONNECTOR TO HANDWHEEL

3 TWISTED PAIRS, INDIVIDUALLY SHIELDED #20 AWG CABLE

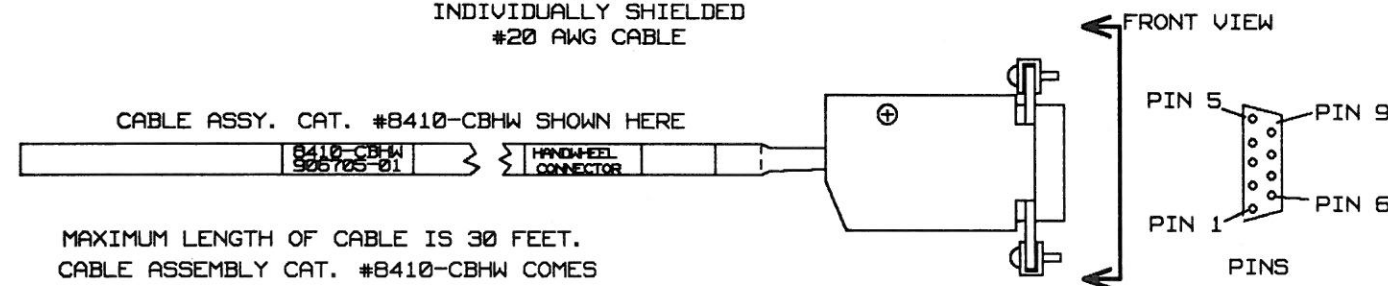

MAXIMUM LENGTH OF CABLE IS 30 FEET. CABLE ASSEMBLY CAT. #B410-CBHW COMES AS A 22 FOOT LENGTH.

# HANDWHEEL CONNECTIONS

Pendant Location

This drawing shows the location of the parts found in the pendant enclosure.

Your control system will have either a monochrome (cat. no. 8410 - XBVD) or color monitor (cat. no. 8410 - XCVD). Monitor connections are shown on the Color Monitor Connections and Location Diagram.

Your system may have the handwheel option (cat. no. 8410 - XHP). Refer to the Handwheel Connections Diagram.

The E-Stop switch (cat. no. 8000 - XESS) is referenced on the Typical E-Stop Wiring Diagram.

Front panel board connections are found on the following diagrams:

- o Front Panel Connector Location Diagram
- o Keyboard Interconnection Diagram
- o Front Panel Lamp Connection Diagram

The spindle speed override switch, feedrate override switch, and front panel lamps are shown here but come prewired. They require no additional wiring.

The AC terminal strip and grounding stud are detailed on the Pendant AC Terminal Block Connections Diagram.

REAR VIEW (COVER NOT SHOWN)

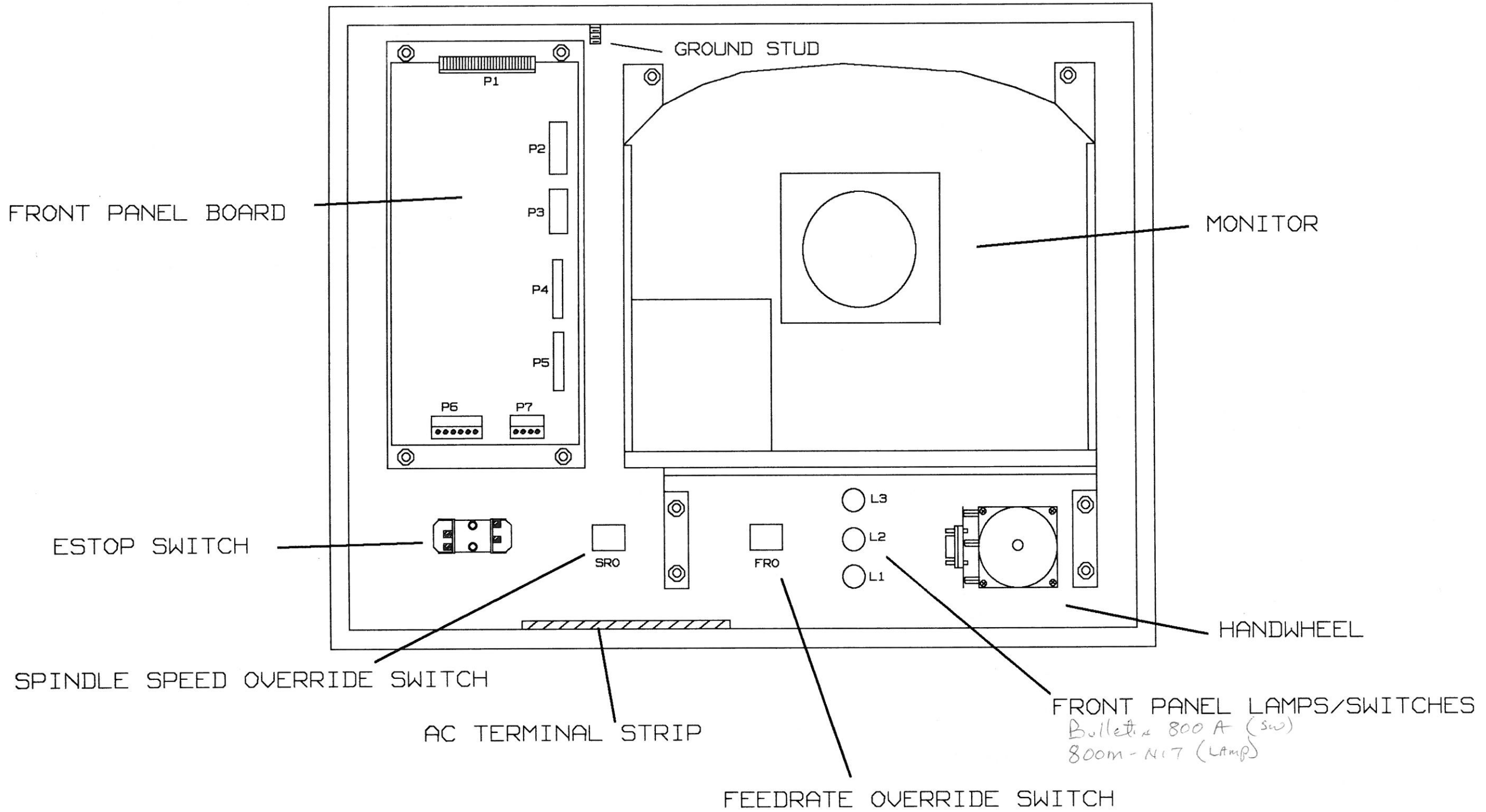

PENDANT LOCATION DIAGRAM

Color Monitor  
Connections And  
Location Diagram

You use this drawing to integrate the color display monitor option (cat. no. 8410-CLR) to the control. This diagram provides you with AC power and signal connection information.

Color Signal  
Connection

To provide color signal information, you connect the color signal cable (cat. no. 8410-CBCC) to the connector located on the side of the monitor chassis. The lower left quadrant of the diagram provides the details of this connector location.

You also connect the ground wire from the color signal cable to a chassis screw located on the side of the monitor. (The screw is indicated on the side view of the chassis.) To connect the ground wire to the screw, you:

1. Remove the screw, and attach the ring lug of the ground wire to the screw.
2. Replace and retighten the screw.

The other end of the color signal cable is terminated at the CPU board. See the CRT Video Signal Connection Diagram for more information.

AC Power  
Connection

You can use either Allen-Bradley cabling (cat. no 8410-ACLR) or user specified wiring to provide 120VAC (+10% - 15%) to the color monitor. The Allen-Bradley supplied cable is 1.5 feet, and mates with the 3 pin, keyed molex connector found accompanying the monitor assembly. (The color monitor assembly comes with approximately 8" of AC power wires to be terminated at a 4 pin molex connector.) Terminate the other end of the cable at the AC distribution terminal mounted on the inside of the pendant enclosure.

Terminate the AC high wire (black) to the AC high terminal, and the AC lo wire to the AC lo terminal. Connect the green chassis ground wire to the chassis ground stud located at the top of the pendant. See the Pendant AC Terminal Block Connections Diagram for further information.

If you choose to provide your own AC cable to the pendant, the wire terminations and specifications will be the same. You will also need to provide a 3 pin molex connector and a ring lug for chassis ground (#18 AWG wire for a #10 stud size.) You will also need special crimp tools for the connector terminations.

This diagram also includes the location of the color monitor AC input fuse. If you need to replace this fuse, replace it with a 3 amp 125 VAC rating fuse.

The adjustable brightness control is shown on the side view of the chassis

**Important:** Do not adjust any internal monitor controls. They are factory adjusted.

# BACK VIEW OF COLOR DISPLAY MONITOR

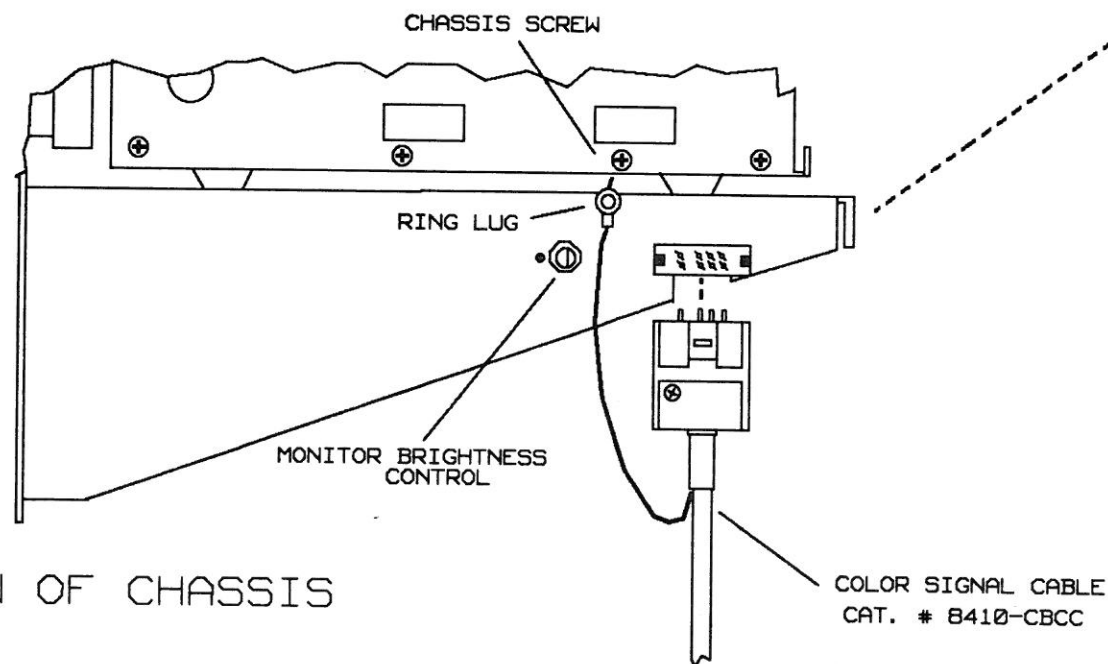
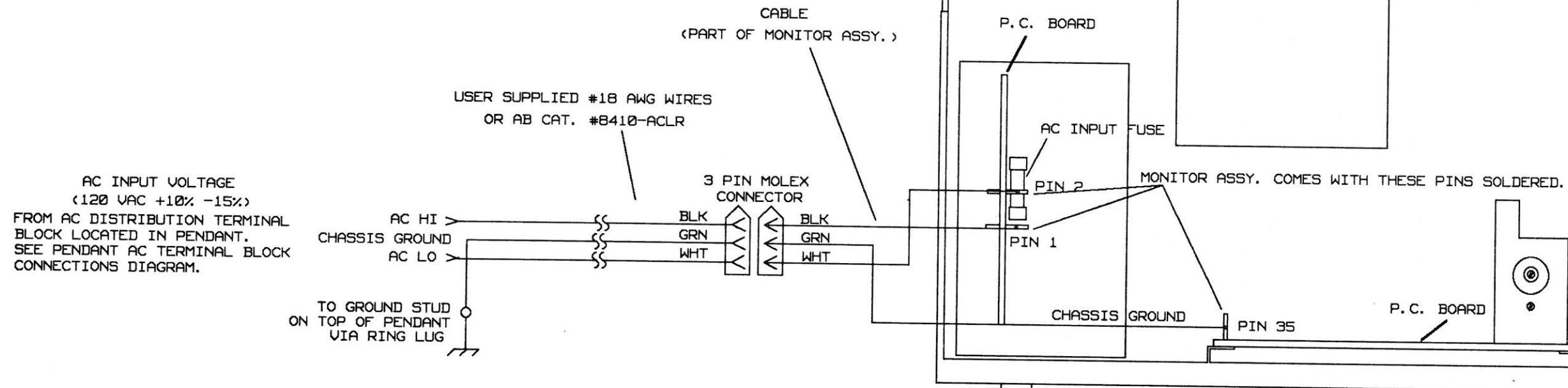

SIDE VIEW OF CHASSIS

COLOR MONITOR CONNECTIONS  
AND LOCATION DIAGRAM

Monochrome Monitor  
Connection and  
Location

This drawing shows you how to make the AC power and signal connections to the monochrome monitor (cat. no. 8410 - XBVD).

Video Signal  
Connection

1. Connect the monochrome monitor cable (cat. no. 8410 - CBBW) to the top BNC connector on the back of the display. This connector is labelled VIDEO IN. (Refer to the CRT Video Signal Connection Diagram for monochrome CRT cable connections.) The other BNC connector is not used.

2. Locate the 2-position switch that is just below the VIDEO IN connector on the back of the display. Set the switch to the 75 ohm position.

AC Power Connection

You need to install an AC power cable (120V AC +10% -15%) to the monitor. You can use A-B Cable (cat. no. 8410 - ACMO) or make your cable. The A-B cable is approximately 1.5 feet long with a 6-pin connector attached. See the AC Power Cable for Monochrome CRT Diagram.

The monitor comes with approximately 5 inches of AC power wires attached to a 6-pin keyed connector.

If you use the A-B cable, follow this procedure:

1. Attach the open end of the cable to the AC distribution terminal mounted on the inside of the pendant enclosure. See the Pendant AC Terminal Block Connection Diagram.
2. Connect the AC high wire (black wire) to the AC high terminal (#8).
3. Connect the AC low wire (white wire) to the AC low terminal (#3).
4. Connect the green chassis ground wire to the chassis ground stud located at the top of the pendant. See the Pendant AC Terminal Block Connection Diagram.

If you provide your own AC cable to the pendant, the procedure is the same but you will have to supply your own 6-pin Molex connector and a ring lug (#10 stud size and #18 AWG wire). Be sure to note the jumper connections between pins 4 and 6 and between pins 3 and 1. You will also need a special crimp tool for the connector terminations.



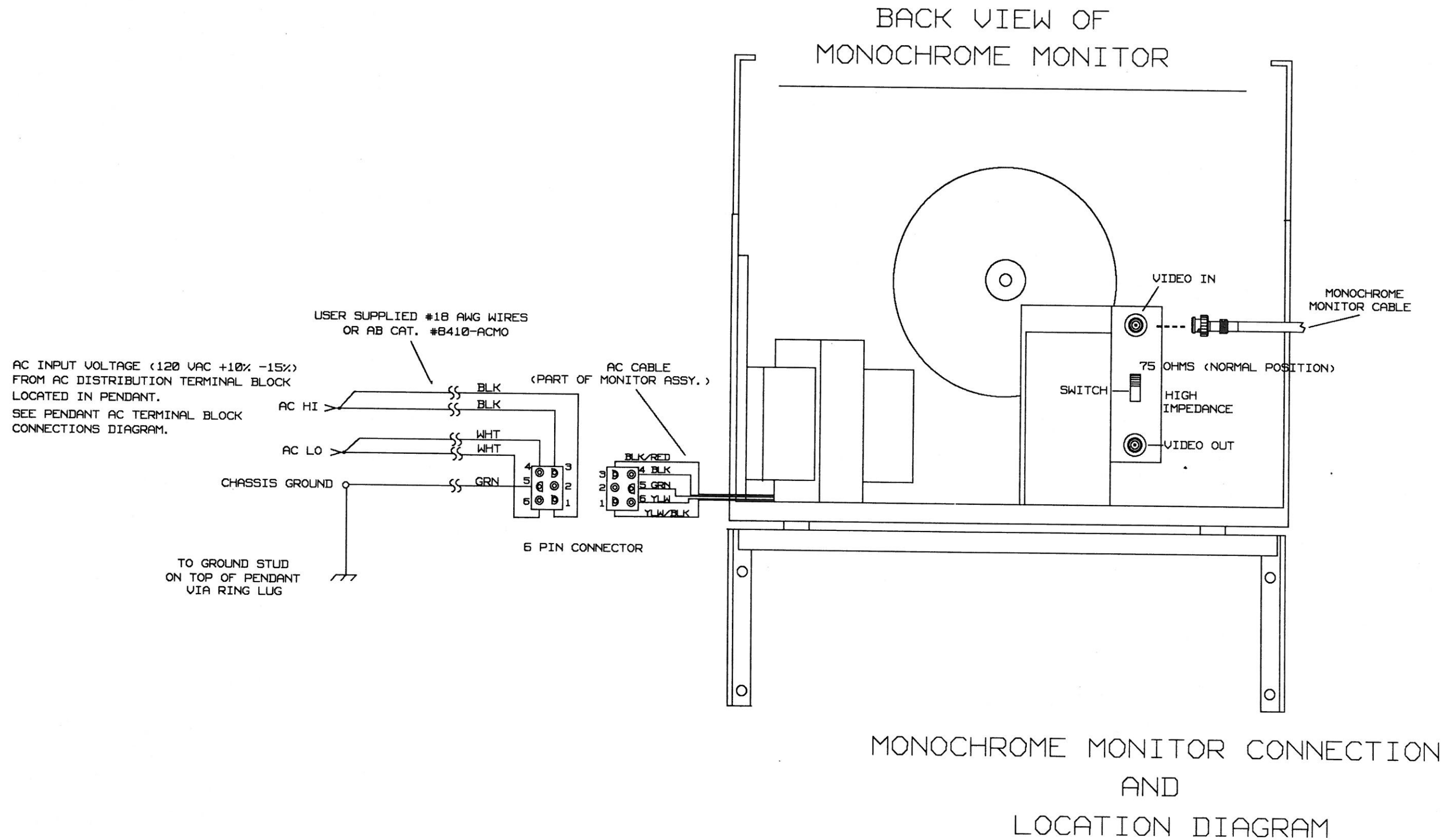

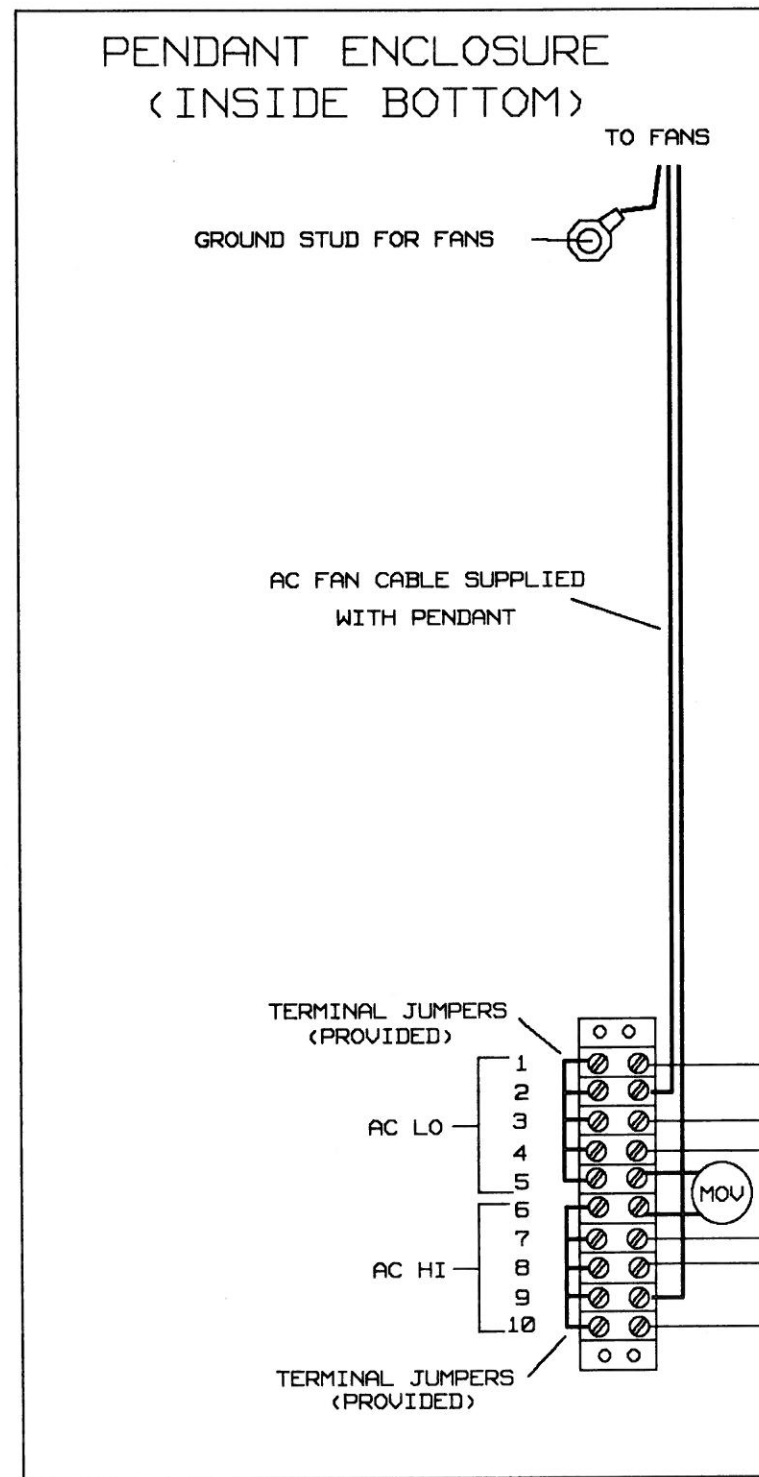
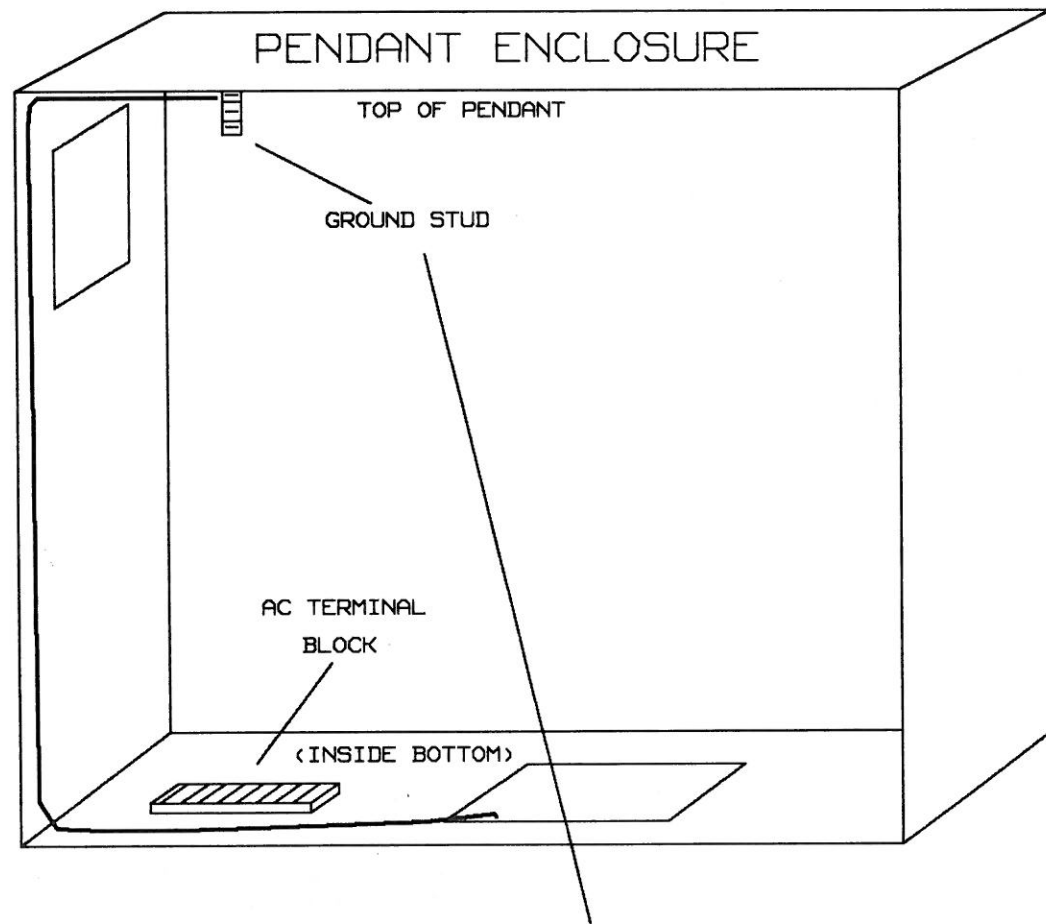

AC TERMINAL BLOCK DESIGNATIONS	
TERMINAL NUMBER	DESIGNATION
1	AC INPUT <LO>
2	FAN AC <LO>
3	MONITOR AC <LO>
4	PERIPHERAL PNL AC <LO>
5	MOV AC <LO>
6	MOV AC <HI>
7	PERIPHERAL PNL AC <HI>
8	MONITOR AC <HI>
9	FAN AC <HI>
10	AC INPUT <HI>

TERMINALS 1, 2, 3, 4, AND 5 SHORTED TOGETHER.  
TERMINALS 6, 7, 8, 9, AND 10 SHORTED TOGETHER.

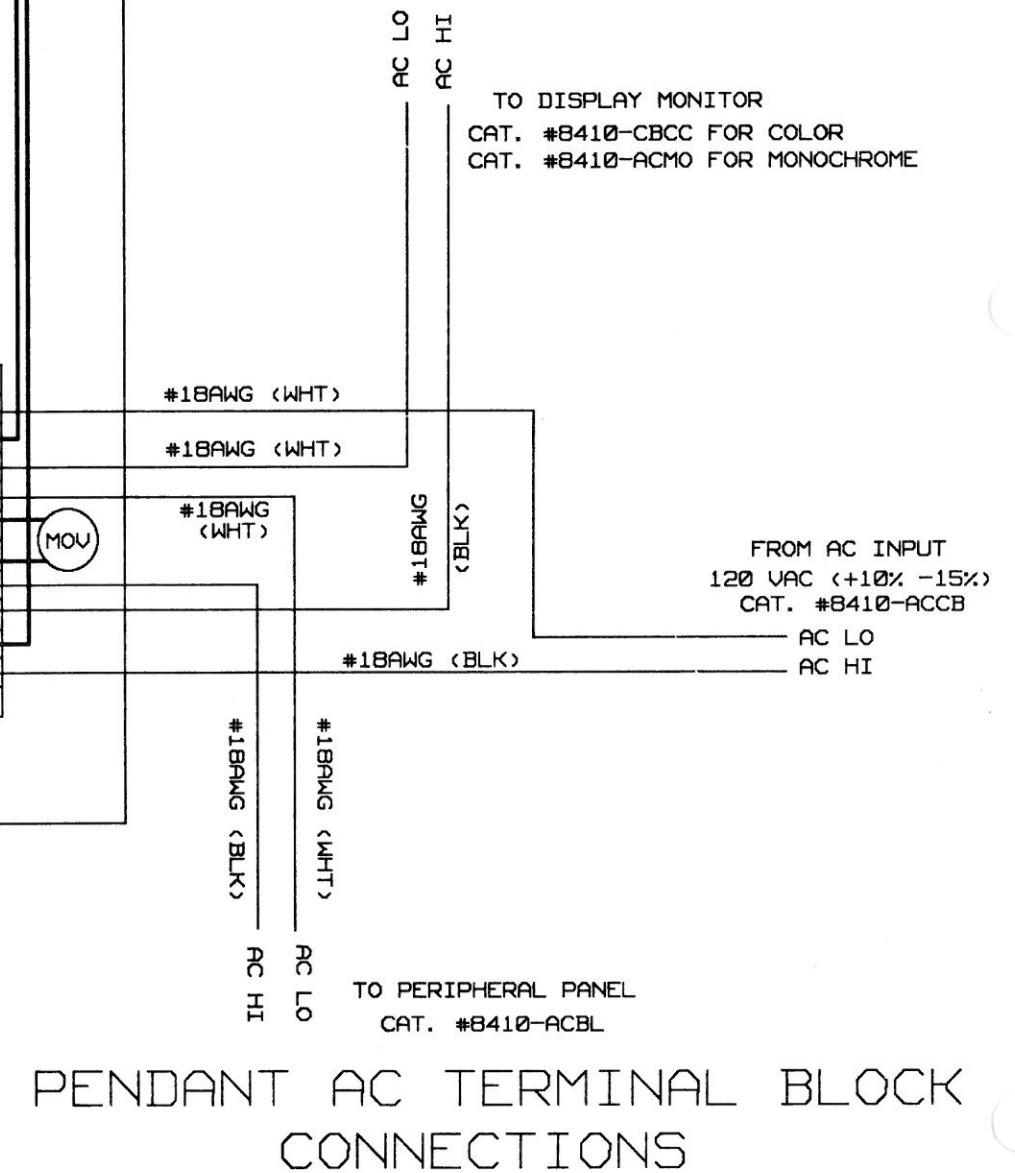
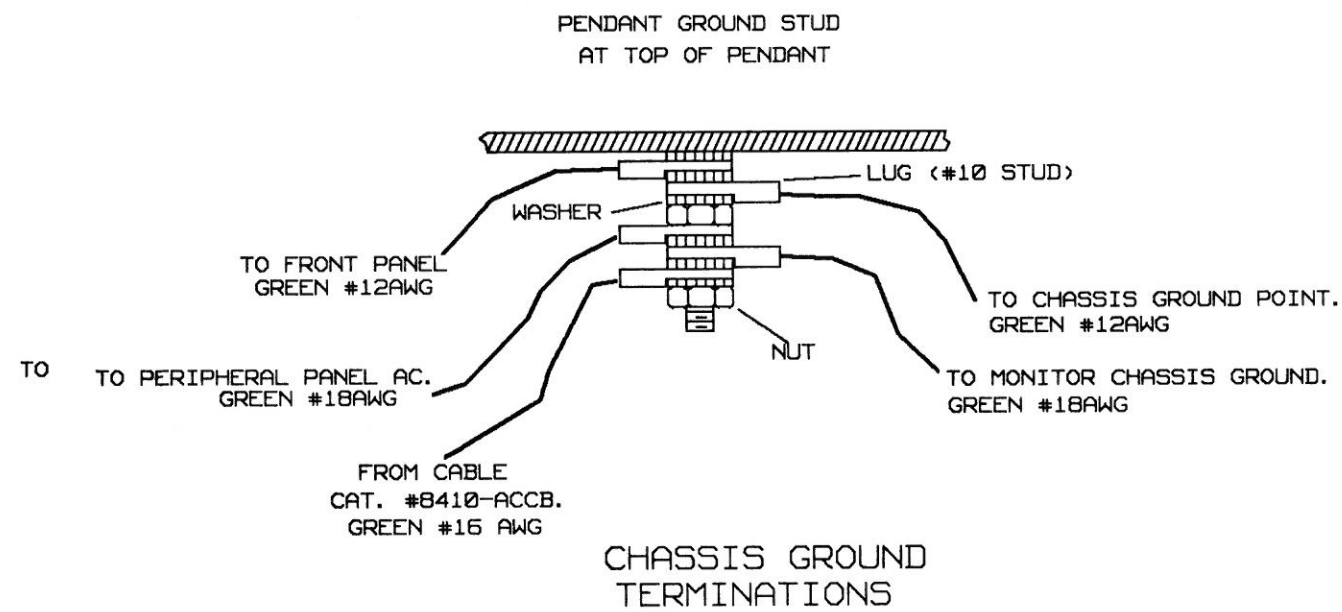

Front Panel  
Connector Location  
Diagram

This diagram displays the two connectors you must wire for the front panel. The two plug-in terminal blocks provide the connections to the serial keyboard from the control, and the connections to the front panel pendant lamps. The other connections shown in the drawing are connected to the proper cabling prior to leaving the factory if you purchased either a pendant or rack version of the operator panel.

The front panel board is located within the pendant next to the monitor. You can access the front panel board by opening the back panel of the pendant. For the location of the front panel board in the pendant, see the Pendant Wiring and Locations Diagram.

For quicker installation, remove the plug-in terminal blocks before you insert the cable wires into the connector. (See the Keyboard Interconnection Diagram and the Front Panel Lamp Connections Diagram.) After you have prepped and tightened the the cable wires in the separated blocks, snap the terminal blocks back into place. This completes the integration of the front panel board. The two connectors are keyed and easily identified by their different lengths, to prevent improper insertion.

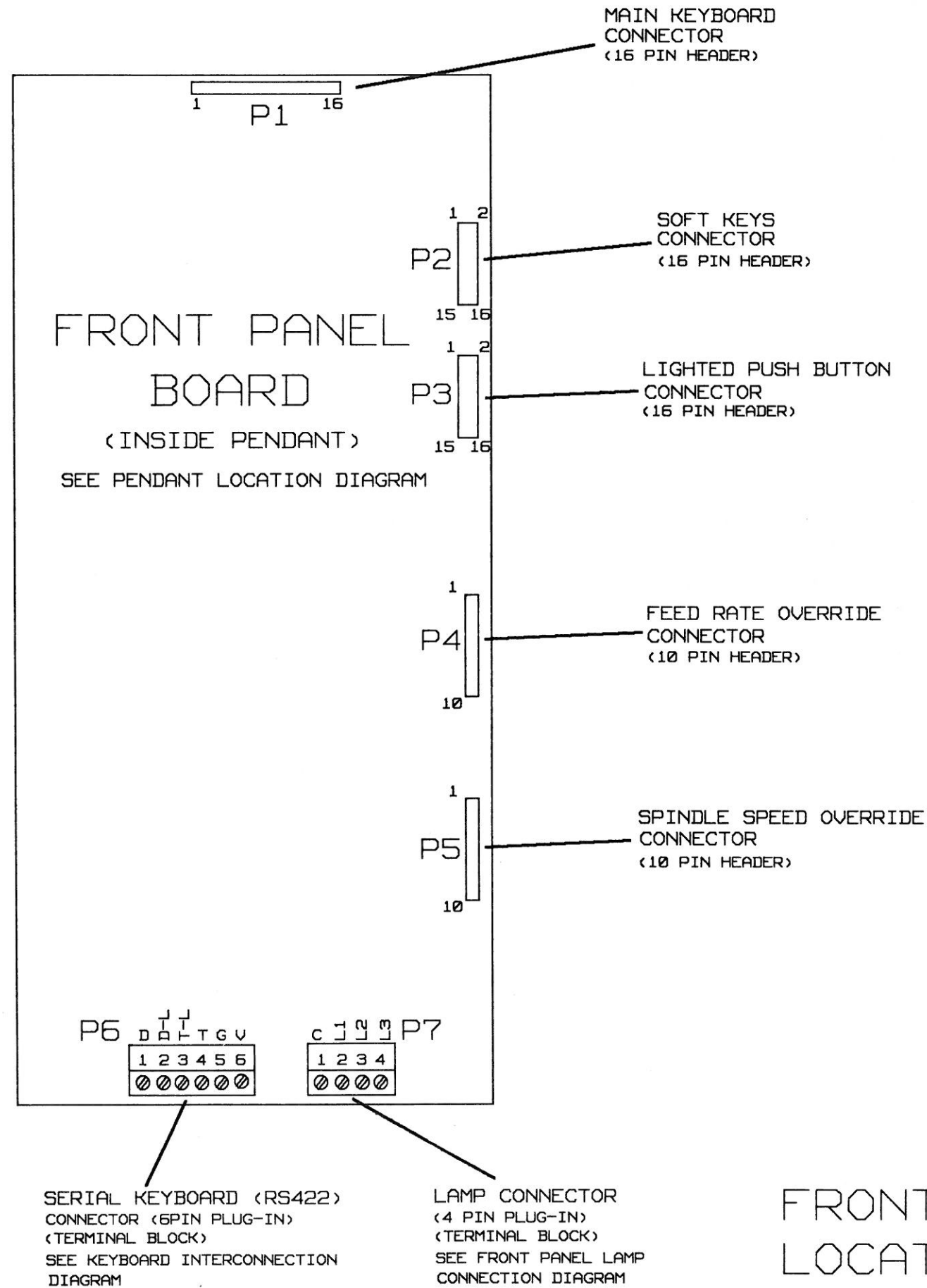

FRONT PANEL CONNECTOR LOCATION DIAGRAM

Keyboard  
Interconnection  
Diagram

You must install a cable between the pendant (keyboard) and the control. You need a three twisted pair, #20 AWG shielded wire to complete the connection or the A-B ready made cable (cat. no. 8410 - CBKY). See the Serial Keyboard Cable Diagram. You can determine the length of the cable based on the system's requirements, based on the distance between the pendant and the CPU board. The maximum length of this cable is 30 feet.

You can terminate the cable shield by twisting together any drain wires before inserting them into the plug-in terminal labelled P7 on the CPU board.

Cut the shield flush (with the cable jacket) that is terminated at connector P6 on the front panel board.

**Important:** Cover any exposed braid or shield wires with heat shrink tubing or electrical tape to prevent stray wire strands from causing electrical shorts.

Strip 1/4 inch of insulation from both ends of the remaining signal wires. Twist the strands together and insert the wire into the terminal. Tighten the screw to secure the wire into the connector. If you have removed the terminal blocks, reinstall them into their proper connectors.

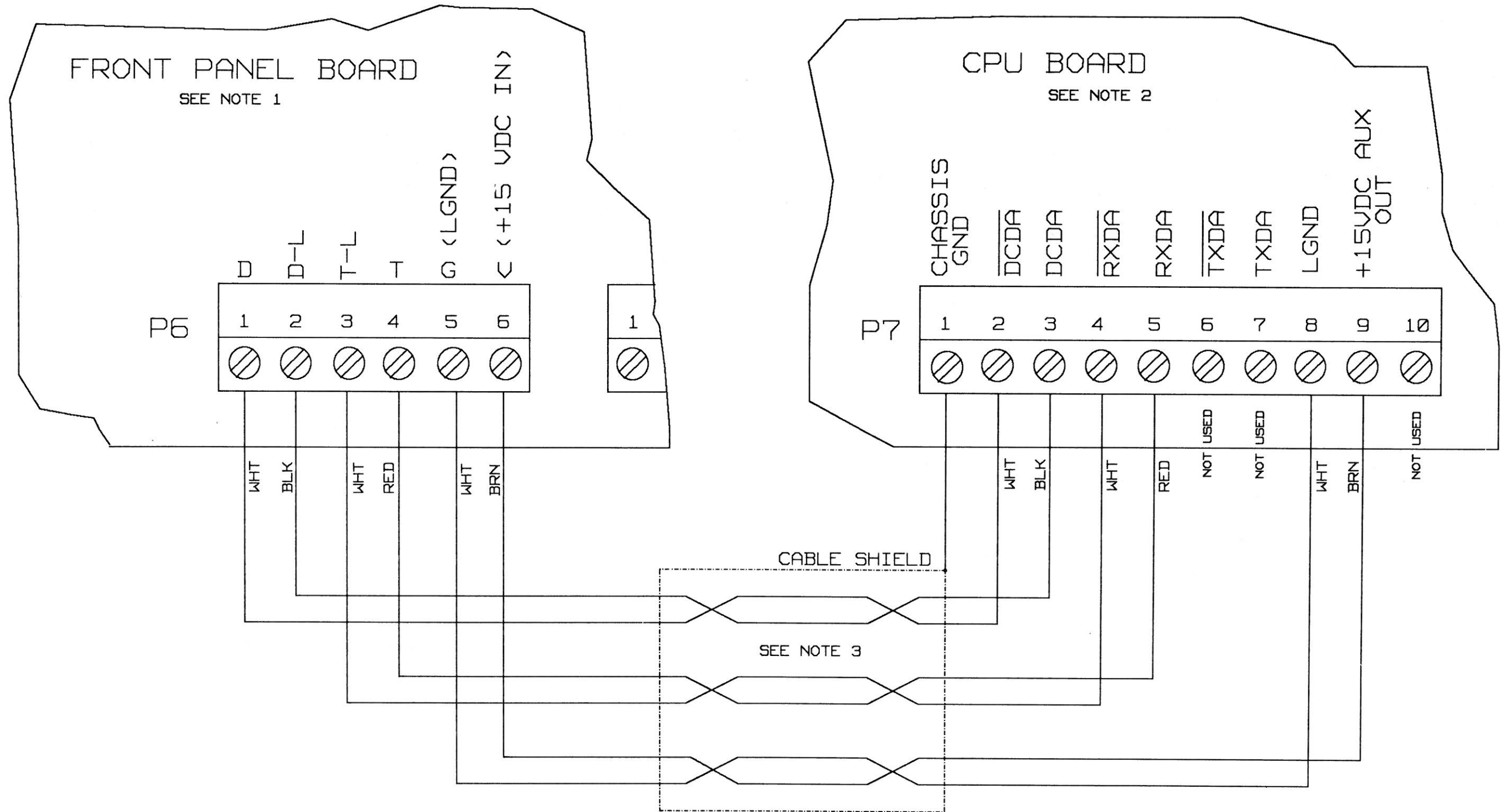

NOTE 1. SEE FRONT PANEL CONNECTOR LOCATION DIAGRAM.

NOTE 2. SEE CPU/CRT CONNECTOR LOCATION DIAGRAM.

NOTE 3. USER SUPPLIED CABLE OR AVAILABLE AS CAT. #8410-CBKY. USE 3 TWISTED PAIR, #20 AWG SHIELDED CABLE OF A MAXIMUM CABLE LENGTH OF 30 FEET. WIRE COLOR CODES MAY VARY WITH CABLE MANUFACTURER. CABLE CAT. #8410-CBKY IS A 22 FOOT LENGTH.

## KEYBOARD INTERCONNECTION DIAGRAM

## Front Panel Lamp Connections

This sheet shows the connections needed to light the CYCLE START, BLK/BLK, and CYCLE STOP buttons on the front panel of the control. Wiring is between the front panel module in the pendant and a user defined I/O board.

The connections shown reflect those required when standard Bandit IV PAL and a 24 point I/O board (cat. no. 8400 - XS1) are used.

The I/O board should have 3 DC output modules similiar to cat. no. 8400 - XSD0. The I/O board should be connected to P6 on the CRT module, for standard PAL, through a 50 conductor I/O cable. See the I/O Connection Diagram.

There are two ways you can connect the I/O board with the lamp connector, P7, on the front panel module:

- o #16 stranded wire or user supplied cabling
- o cat. no. 8410-CBPL -- a 22 foot cable that has 4 conductors

A ready made 22 foot cable (cat. no. 8410-CBPL) is available from A-B. See the Indicator Light Cable Diagram. One end is not stripped so you can cut it to the proper length. Strip the insulation 1/4 in. from this end, twist the strands and insert them under the pressure plate of the barrier strip of I/O board. Follow the color coding shown.

If you decide to use #16 wire or user supplied cabling, keep the individual wire lengths to less than 30 feet. Strip 1/4 in. from the end of each wire, twist the strands and insert them into P7 and the barrier strip of the I/O board.

The DC output modules require +24V DC  $\pm$  5% to properly light the buttons. You can use the +24V DC/VUR from the 8400-PSB power supply for this. Use #16 AWG wire for connecting the power supply to the I/O board.

**Important:** Connections from P3 on the front panel module and the front panel buttons are provided through an Allen-Bradley supplied cable not shown. This cable comes installed in the pendant.

# FRONT PANEL BOARD

SEE FRONT PANEL CONNECTOR LOCATION DIAGRAM

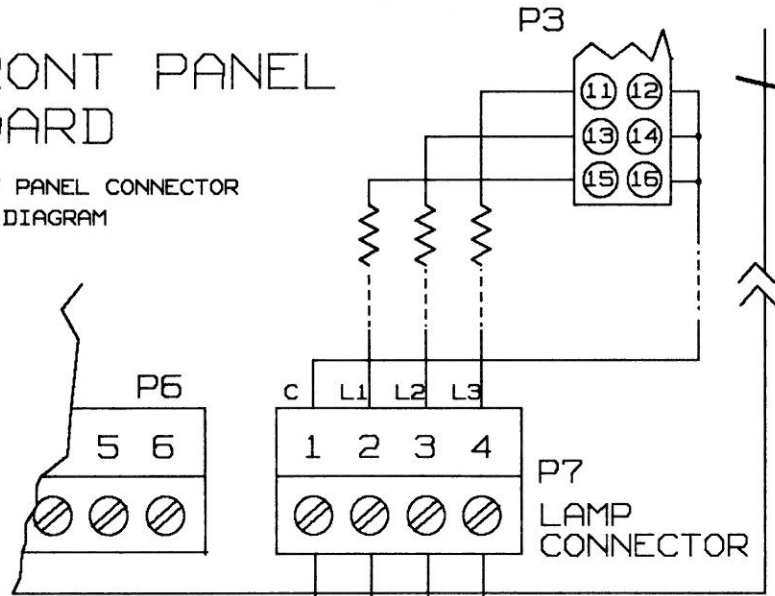

TO FRONT PANEL LIGHTED PUSH BUTTONS

# TYPICAL I/O BOARD

(USER DEFINED)

USER SPECIFIED OUTPUT MODULES

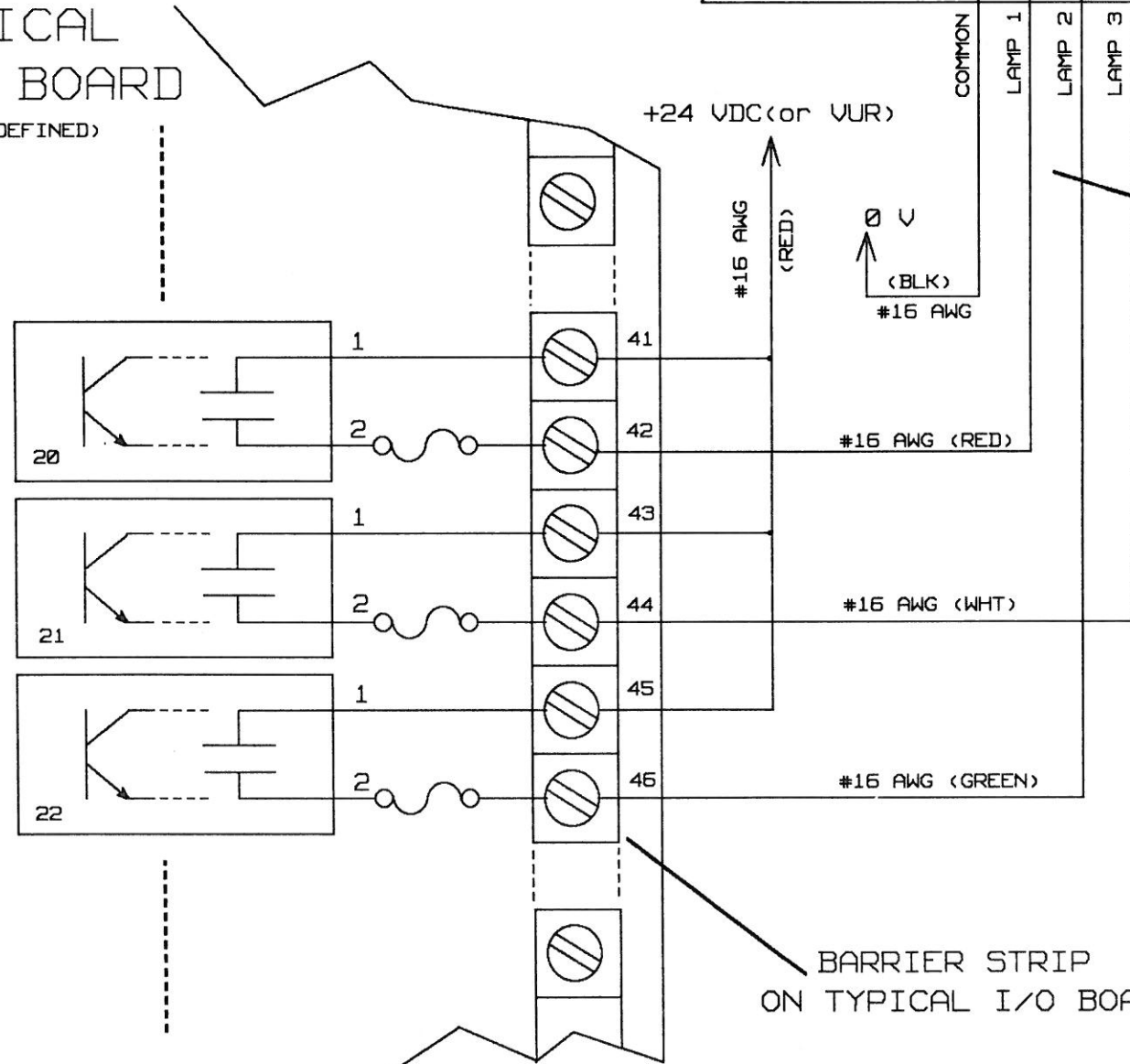

+24 VDC (or VUR)

#16 AWG (RED)

0 V (BLK) #16 AWG

#16 AWG (RED)

#16 AWG (WHT)

#16 AWG (GREEN)

BARRIER STRIP ON TYPICAL I/O BOARD

USE #16 AWG STRANDED WIRE. MAXIMUM LENGTH 30 FEET. COLOR CODING OF WIRE USER PREFERENCE. AVAILABLE AS CABLE CAT. #8410-CBPL, IN A 22 FOOT LENGTH.

### WIRE CHART

COLOR	GAUGE
RED	#16 AWG
GREEN	#16 AWG
WHITE	#16 AWG
BLACK	#16 AWG

+24 VDC (or VUR)

+24 VDC (or VUR)

0V

0V

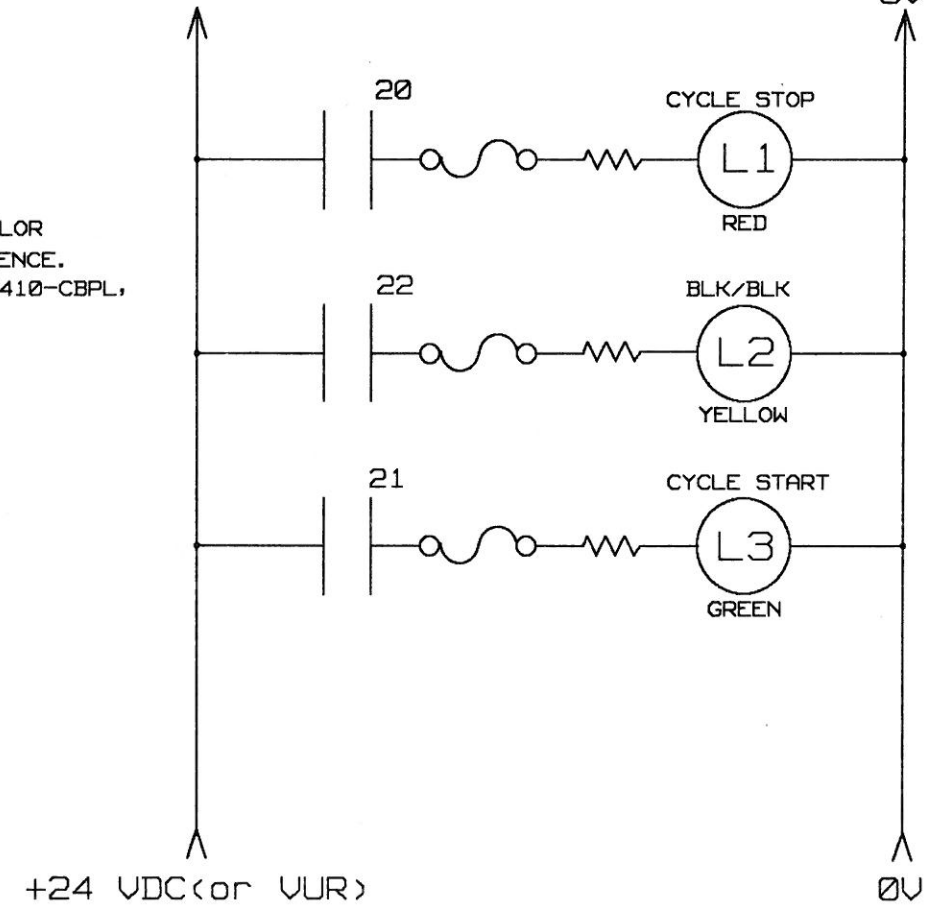

WIRING SHOWN HERE FOR STANDARD PAL WITH 24 POINT I/O BOARD. 50 PIN RIBBON CABLE TO I/O BOARD IS CONNECTED TO P6 OF CRT BOARD.

# FRONT PANEL LAMP CONNECTION DIAGRAM



Typical ESTOP  
Wiring Diagram

This diagram show typical ESTOP wiring for the general control system. Although the number of devices in an ESTOP string vary from application to application, you must do some basic wiring. Minimally, the ESTOP string must be wired to the ESTOP connector located on the CRT board and to the ESTOP switch located on the front panel of the pendant.

The ESTOP connector located on the CRT board interfaces with the ESTOP string to a reed relay. (The status of the reed relay is maintained by the control circuitry.) The recommended maximum current through the reed relay is 100ma (resistive load). Fuse F7 protects the reed relay from any current greater than .25 amps. A solid state relay is required in this string if current loads above 100ma occur through the reed relay.

You must select devices and size wires that are found in the ESTOP string marked with asterisks. #16 AWG wires are recommended to connect the string devices and to wire the ESTOP switch. A 22 foot, two conductor cable (cat. no. 8410-CBES) is available to wire the ESTOP connector into the string.

When using relay coils in an ESTOP string, you should wire a diode around the coil. This prevents back emf generated by the relay coil at de-energization from damaging other components in the string. Note the polarity of the diode and wire as shown at CR1.

You can use an alternate circuit with two zener diodes (each rated at 54 volts) that offer faster relay de-energizing times, while limiting back emf. These connections are shown on the upper left side of the drawing.

NOTE 1. USE OF DIODE WIRED AROUND RELAY COILS RECOMMENDED AS SHOWN. AN ALTERNATE CIRCUIT WIRED IN PLACE OF THE SINGLE DIODE IS SHOWN BELOW. THIS CIRCUIT USING TWO ZENER DIODES (EACH TYP. RATED 54 VOLTS) OFFERS FASTER RELAY DEENERGIZING TIMES. NOTE DO NOT USE ZENER DIODES AND SINGLE DIODE CIRCUIT AT SAME TIME.

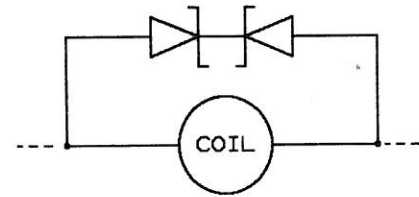

+24 VDC OR VUR

+24 VDC OR VUR

0V (COMMON)

0V (COMMON)

EXTREME OVERTRAVEL SWITCHES \*

OVERTRAVEL STATUS TO PAL

USER REMOTE ESTOP \*

THERMAL CUTOUT \*

ESTOP SWITCH

ESTOP REQUEST TO PAL

\* DENOTES USER DEFINED DEVICES

FROM CPU CONTROL WATCHDOG, ETC.

REED RELAY

RECOMMENDED MAXIMUM CURRENT THROUGH RELAY CONTACTS 100MA.

1/4A FUSE

ON CRT BOARD

ESTOP CONNECTOR

SEE CPU/CRT CONNECTOR LOCATION DIAGRAM

SEE NOTE 1.

CR1 \*

USE OF #14 OR #16 AWG WIRE RECOMMENDED TO ESTOP CONNECTOR.

SEE NOTE 1.

M1 \*

OPTIONAL

DRIVES ON SWITCH \*

CR1 \*

M1 \*

DRIVE STATUS TO PAL (OPTIONAL)

M1 \*

DRIVES \*

TYPICAL ESTOP WIRING DIAGRAM

I/O Board Logic  
Supply Wiring

The I/O boards (cat. no. 8400-XS1 or 8000XQBD) require +5 volts DC to power the configurable plug-in I/O modules. This power requirement is met by using the unused +5VDC output of the 8400-PSB power supply. The return current for the +5VDC conducts through the even pins (2-50) of the 50 pin ribbon connector/cable to the CRT board.

Use a #12 AWG wire to minimize +5 voltage drops to each I/O board daisy chained (series) in the overall system. By daisy chaining the I/O boards together, you can avoid multiple lengths of wire merging at a single terminal. Each daisy chain can have up to three I/O boards, and two chains can be wired to the +5 volt power supply terminal.

The overall wire length per chain (measured from the power supply terminal to the last I/O board) should not exceed 10 feet. You use spade terminal lugs on all terminations to the power supply, and you can use a maximum of two stacked lugs per terminal point. Lugs are not necessary for I/O board terminations, because the wire can be stripped back .25" and inserted underneath the pressure plates of the I/O board terminals.

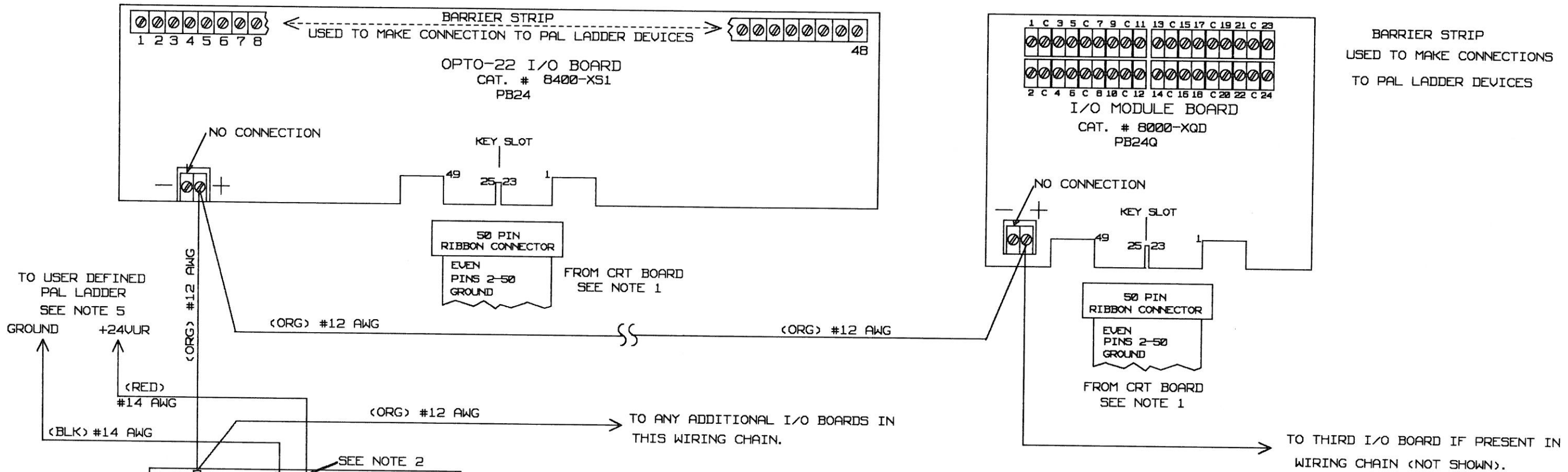

BARRIER STRIP  
USED TO MAKE CONNECTIONS  
TO PAL LADDER DEVICES

TO THIRD I/O BOARD IF PRESENT IN  
WIRING CHAIN (NOT SHOWN).

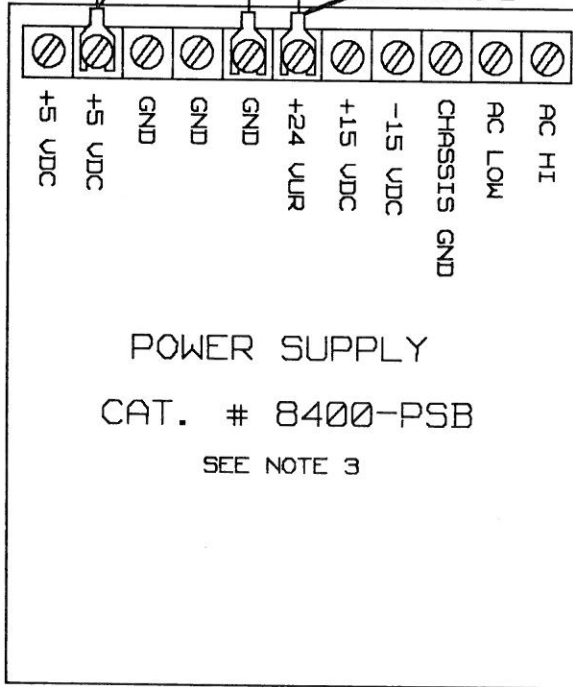

WIRE SPECIFICATIONS		
WIRE	COLOR	AWG
+5	ORANGE	#12
+24	RED	#14
GND	BLACK	#14

CATALOG NUMBERS FOR MODULE TYPES		
MODULE TYPE	SINGLE POINT	FOUR POINT
AC INPUT	8400-XSA1	8000-XQA1
AC OUTPUT	8400-XSA0	8000-XQA0
DC INPUT	8400-XSD1	8000-XQD1
DC OUTPUT	8400-XSD0	8000-XQD0

- NOTE 1. SEE I/O CONNECTION DIAGRAM.
- NOTE 2. USE SPADE TERMINAL LUGS ON ALL TERMINATIONS TO POWER SUPPLY. MAXIMUM OF TWO STACKED LUGS PER SINGLE TERMINAL POINT.
- NOTE 3. SEE POWER SUPPLY INTERCONNECTION DIAGRAM.
- NOTE 4. MAXIMUM OF THREE DAISY CHAINED I/O BOARDS PER WIRING CHAIN, WITH A MAXIMUM OVERALL WIRE LENGTH OF 10 FEET PER CHAIN.
- NOTE 5. USE OF THE +24VUR OUTPUT ON THE POWER SUPPLY FOR THE PAL LADDER IS DETERMINED BY THE USER.

## I/O BOARD LOGIC SUPPLY WIRING DIAGRAM

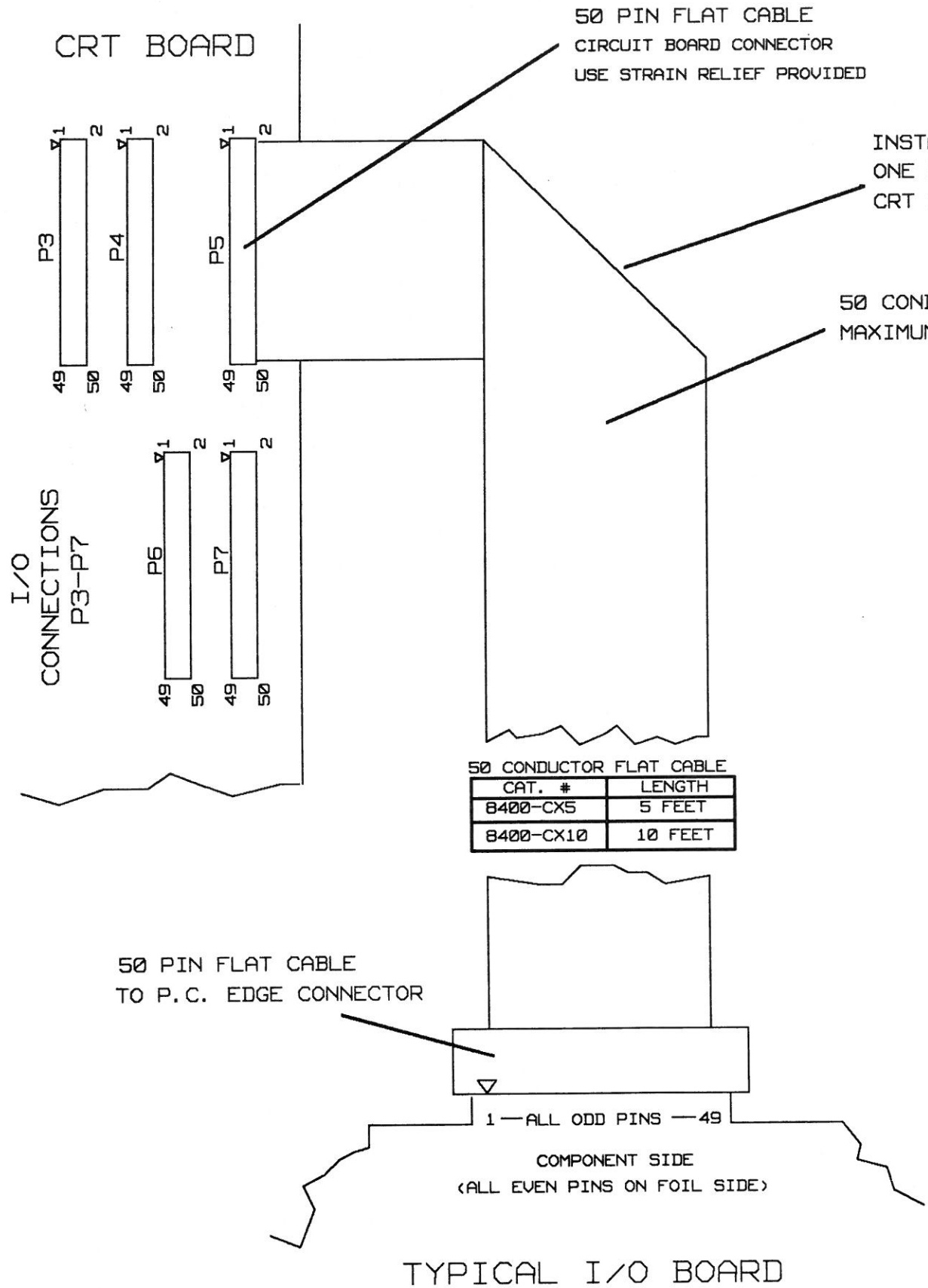

PIN #	I/O CONNECTOR LABELS					OPT0-22 I/O	QUAD I/O MODULE BOARD
	P3	P4	P7	P6	P5		
1	R001	R025	R049	R073	R097	I/O MODULE #	I/O CHANNEL
3	02	26	50	74	98		
5	03	27	51	75	R099		
7	04	28	52	76	R100		
9	05	29	53	77	101		
11	06	30	54	78	102		
13	07	31	55	79	103		
15	08	32	56	80	104		
17	17	41	65	89	113		
19	18	42	66	90	114		
21	19	43	67	91	115		
23	20	44	68	92	116		
25	21	45	69	93	117		
27	22	46	70	94	118		
29	23	47	71	95	119		
31	24	48	72	96	120		
33	09	33	57	81	105		
35	10	34	58	82	106		
37	11	35	59	83	107		
39	12	36	60	84	108		
41	13	37	61	85	109		
43	14	38	62	86	110		
45	15	39	63	87	111		
47	R016	R040	R064	R088	R112		
49	DO NOT USE					DO NOT USE	

ALL EVEN PINS ARE GROUND

NOTE: WHEN ASSIGNING PAL RXXX NUMBERS  
ALL EIGHT RXXX'S IN THAT  
GROUP MUST BE THE SAME DESIGNATION.

### I/O CONNECTION DIAGRAM

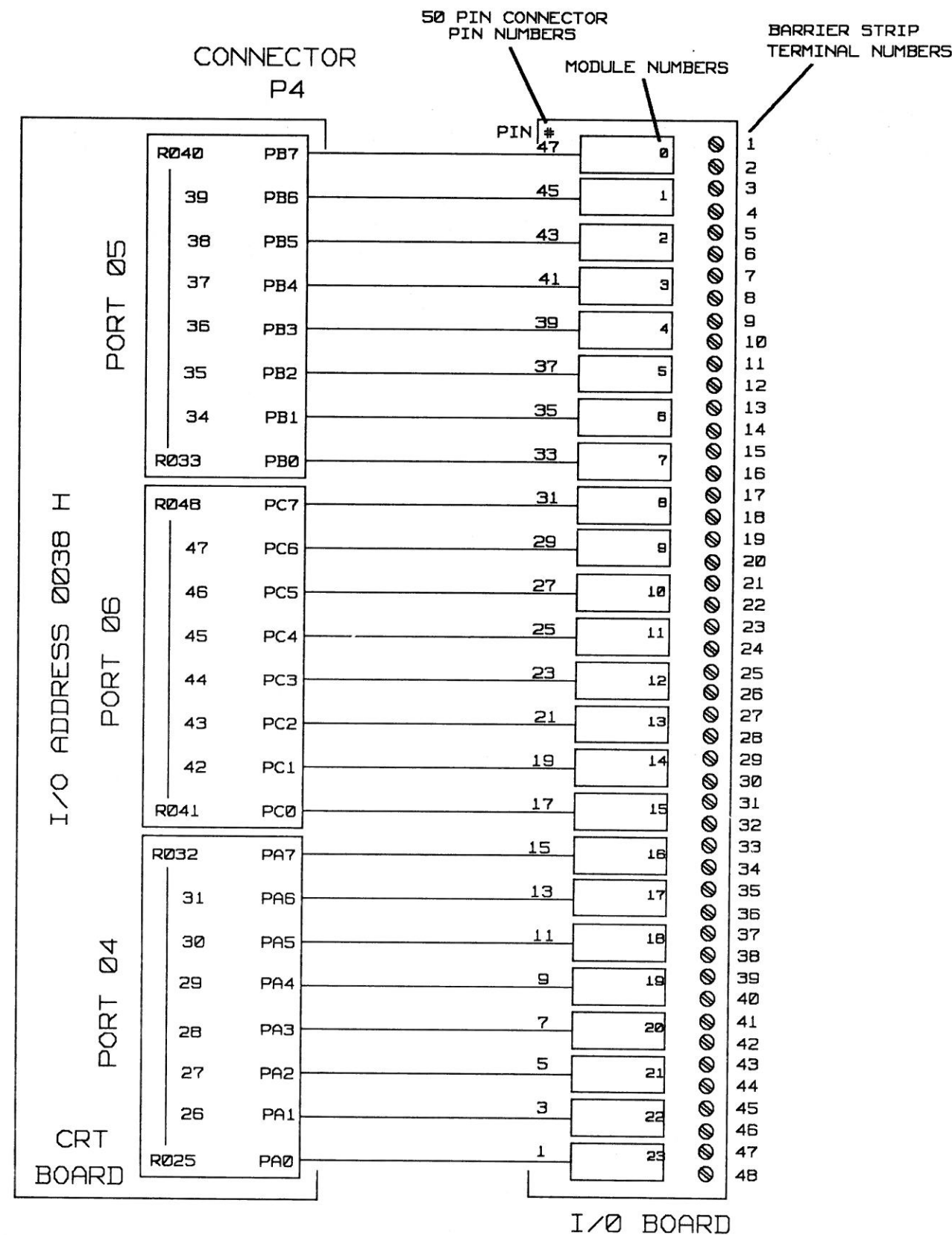
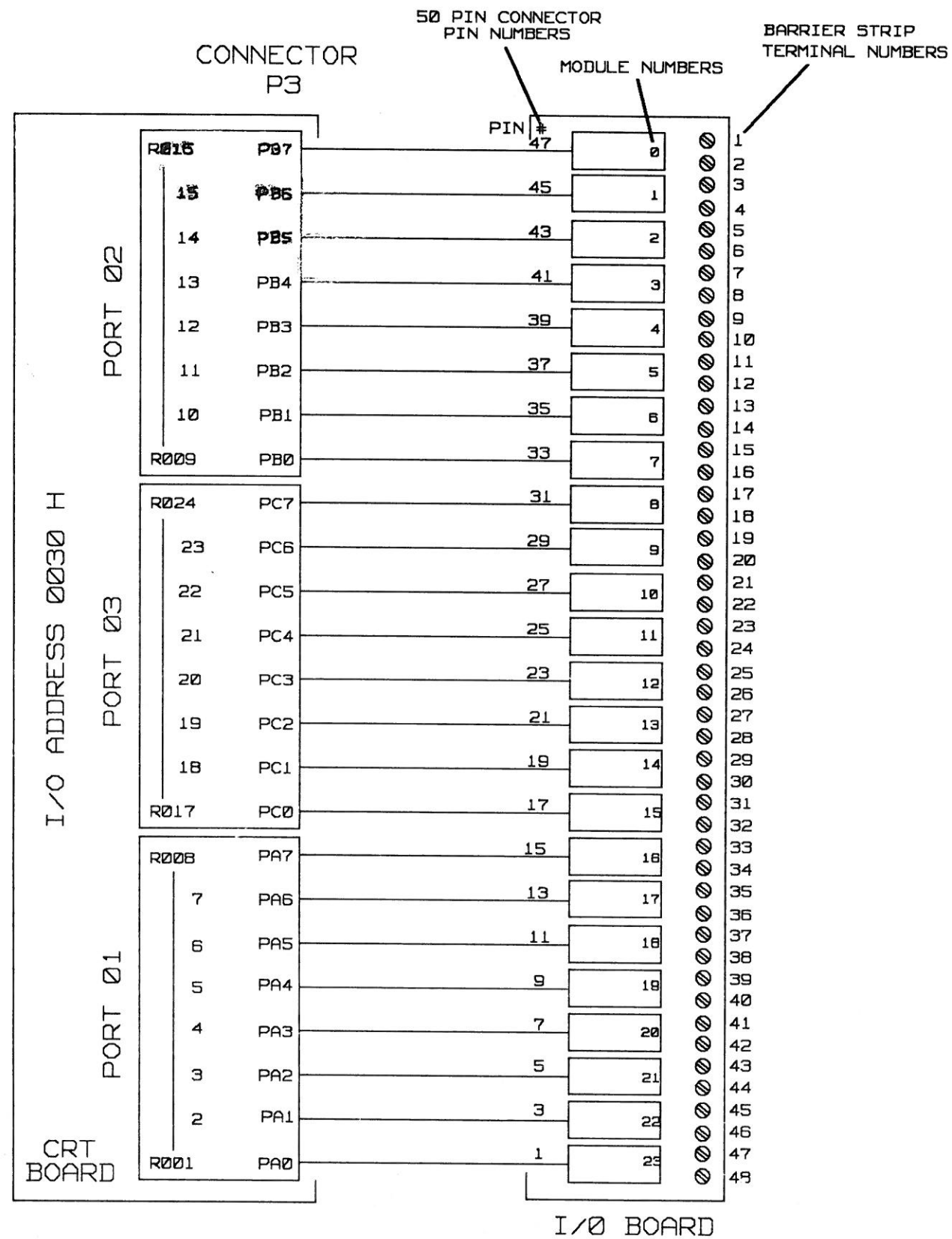

PAL WORKSHEET FOR  
24 POINT I/O BOARD

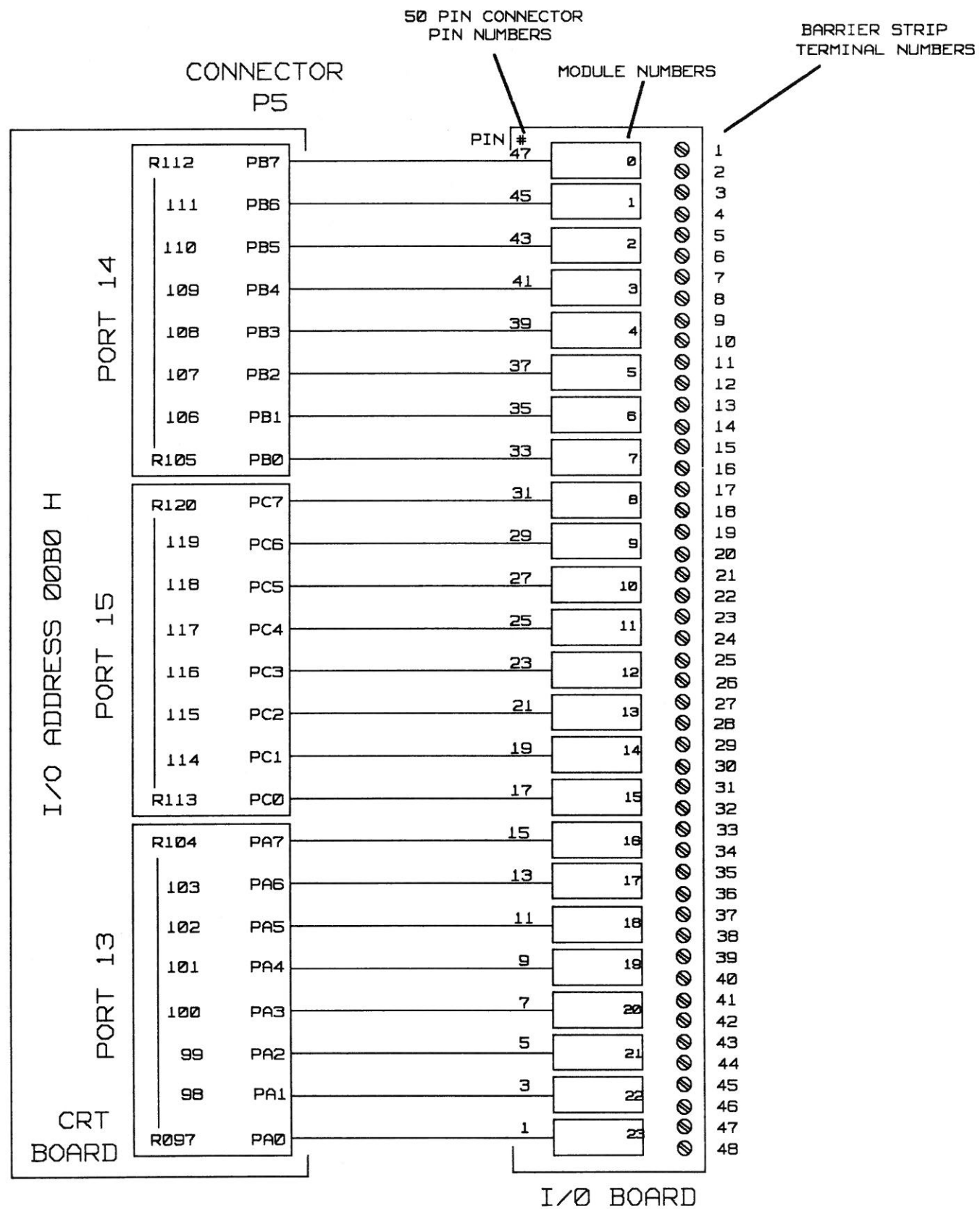

PAL WORKSHEET FOR  
24 POINT I/O BOARD

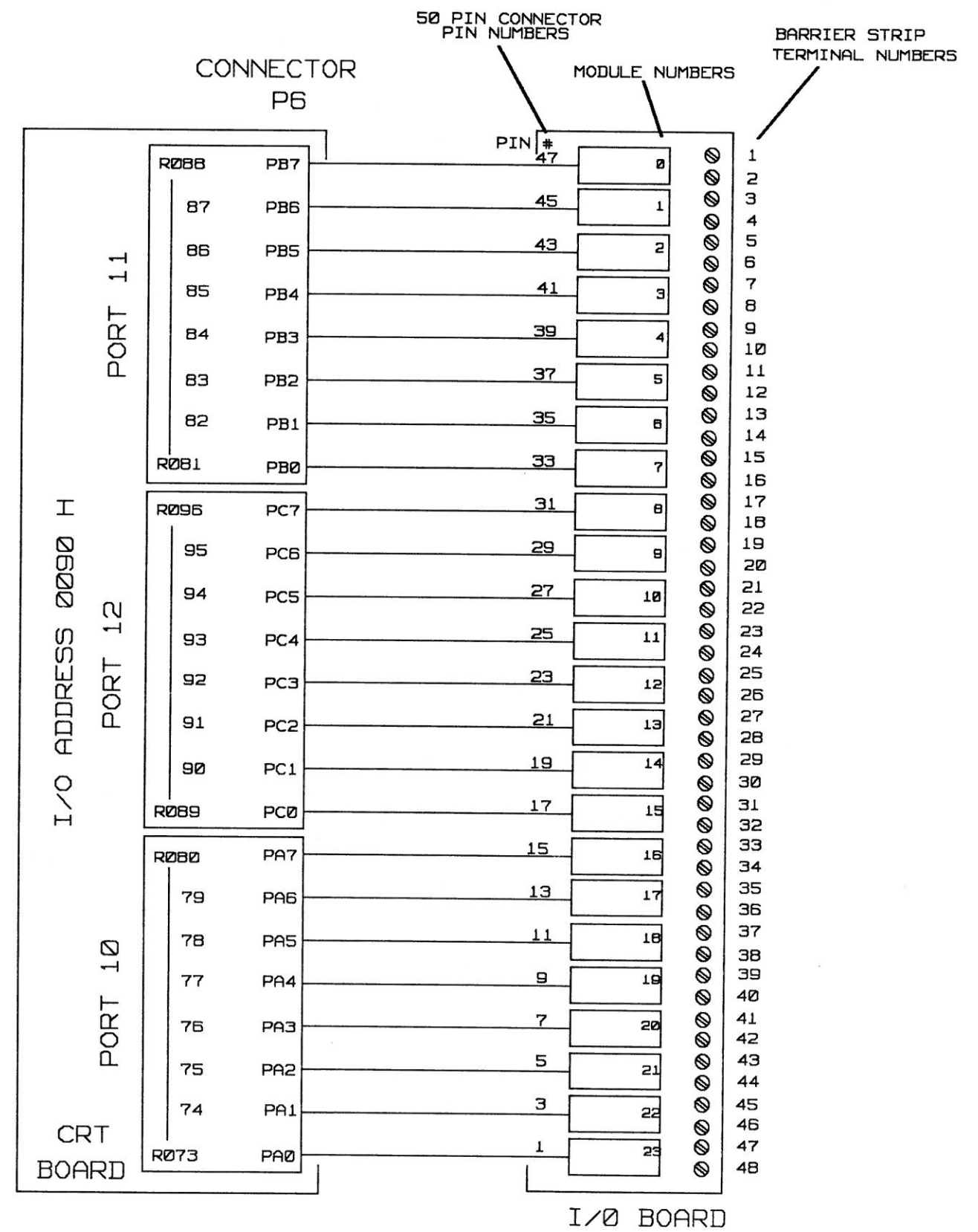
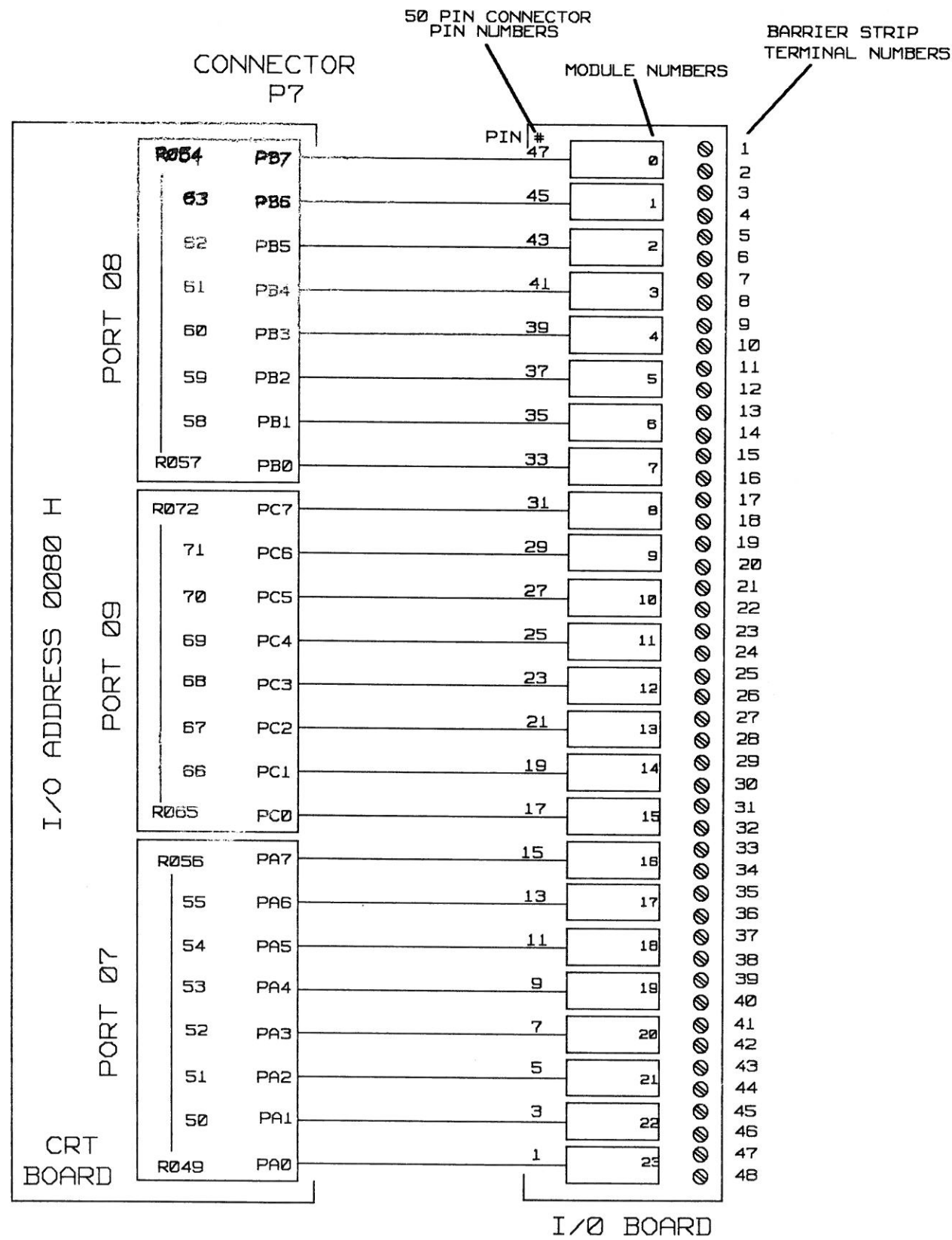

PAL WORKSHEET FOR  
24 POINT I/O BOARD



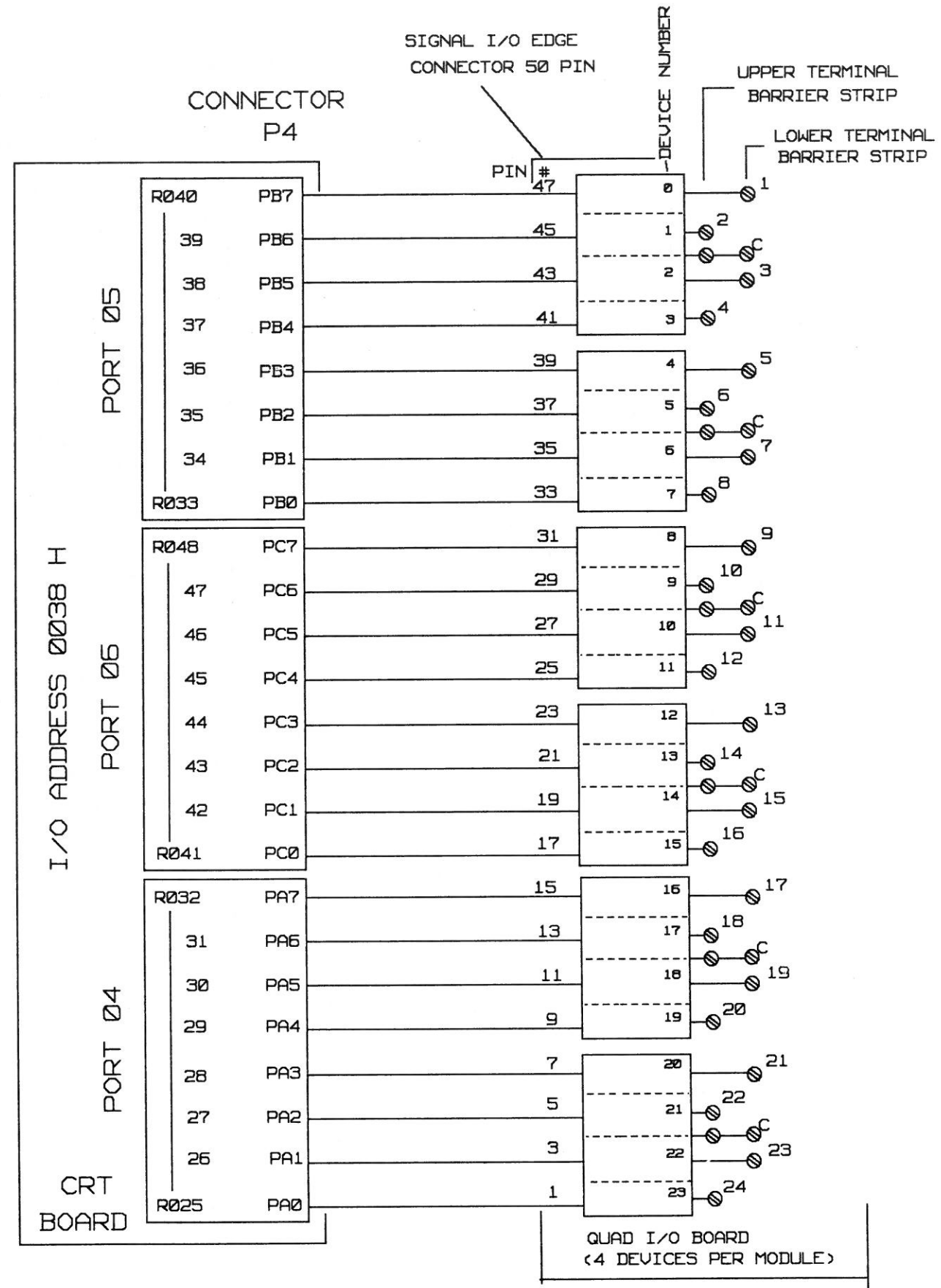
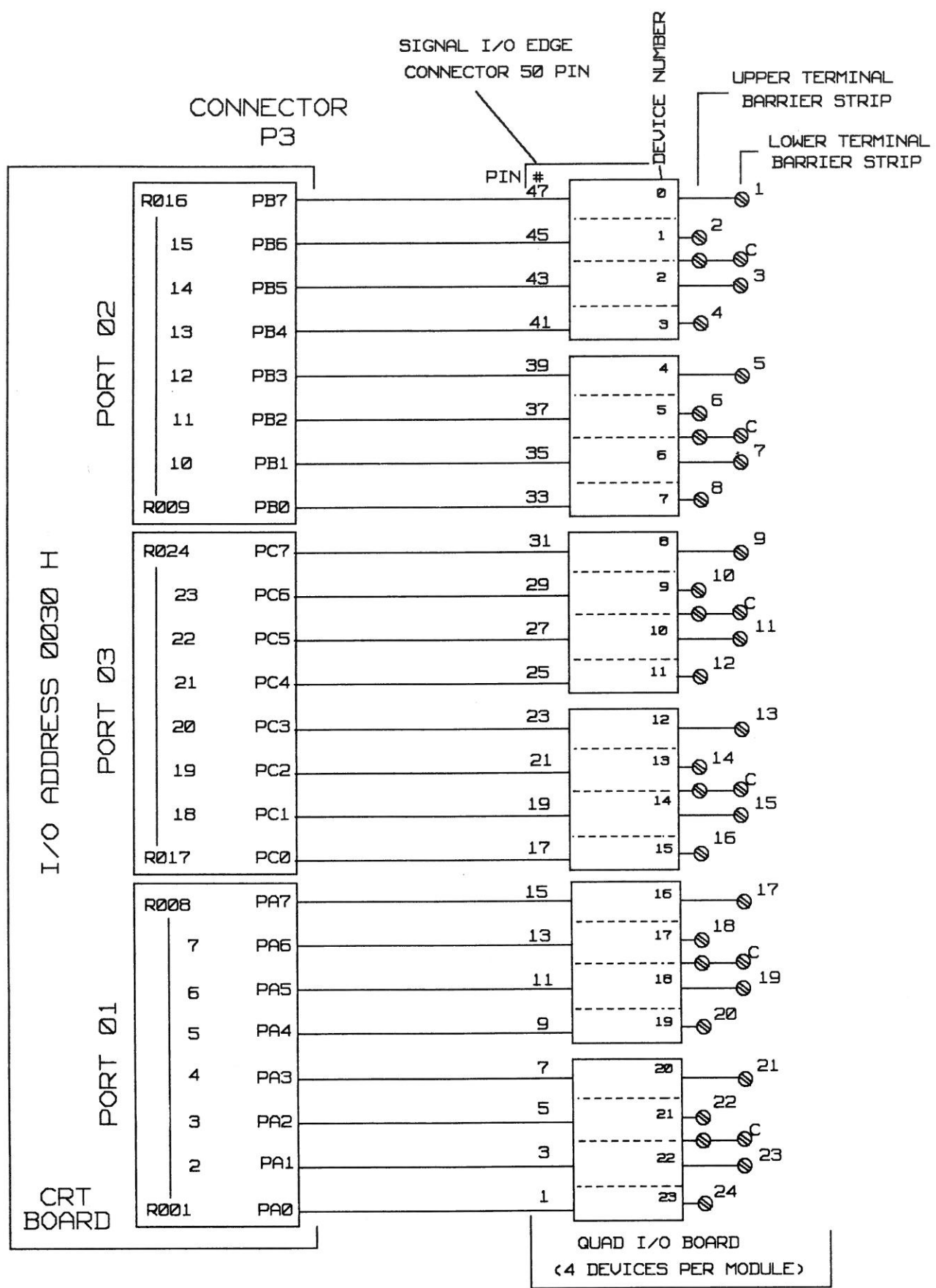

PAL WORKSHEET FOR  
24 PT. QUAD PACK I/O BOARD

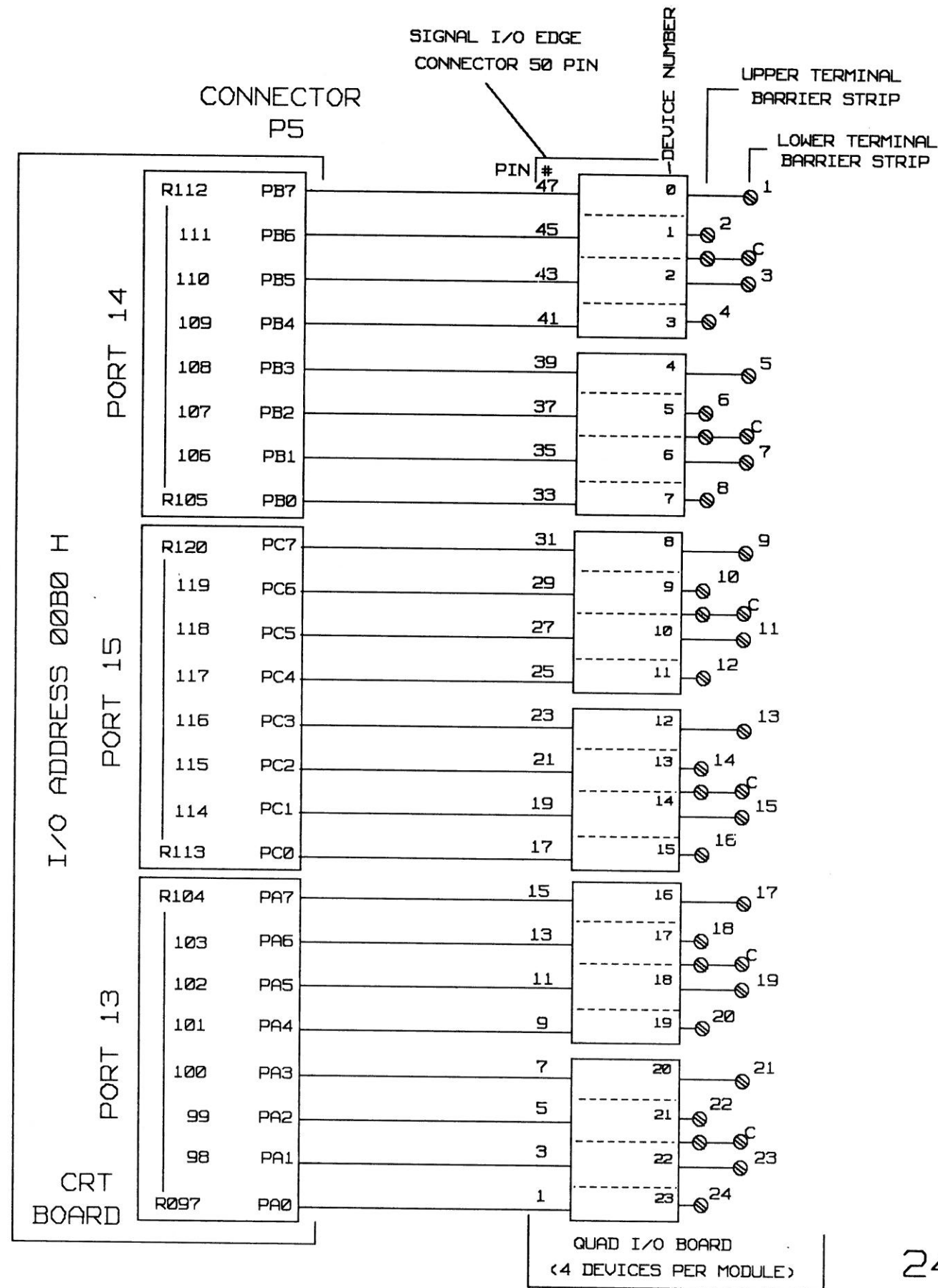

PAL WORKSHEET FOR  
24 PT. QUAD PACK I/O BOARD

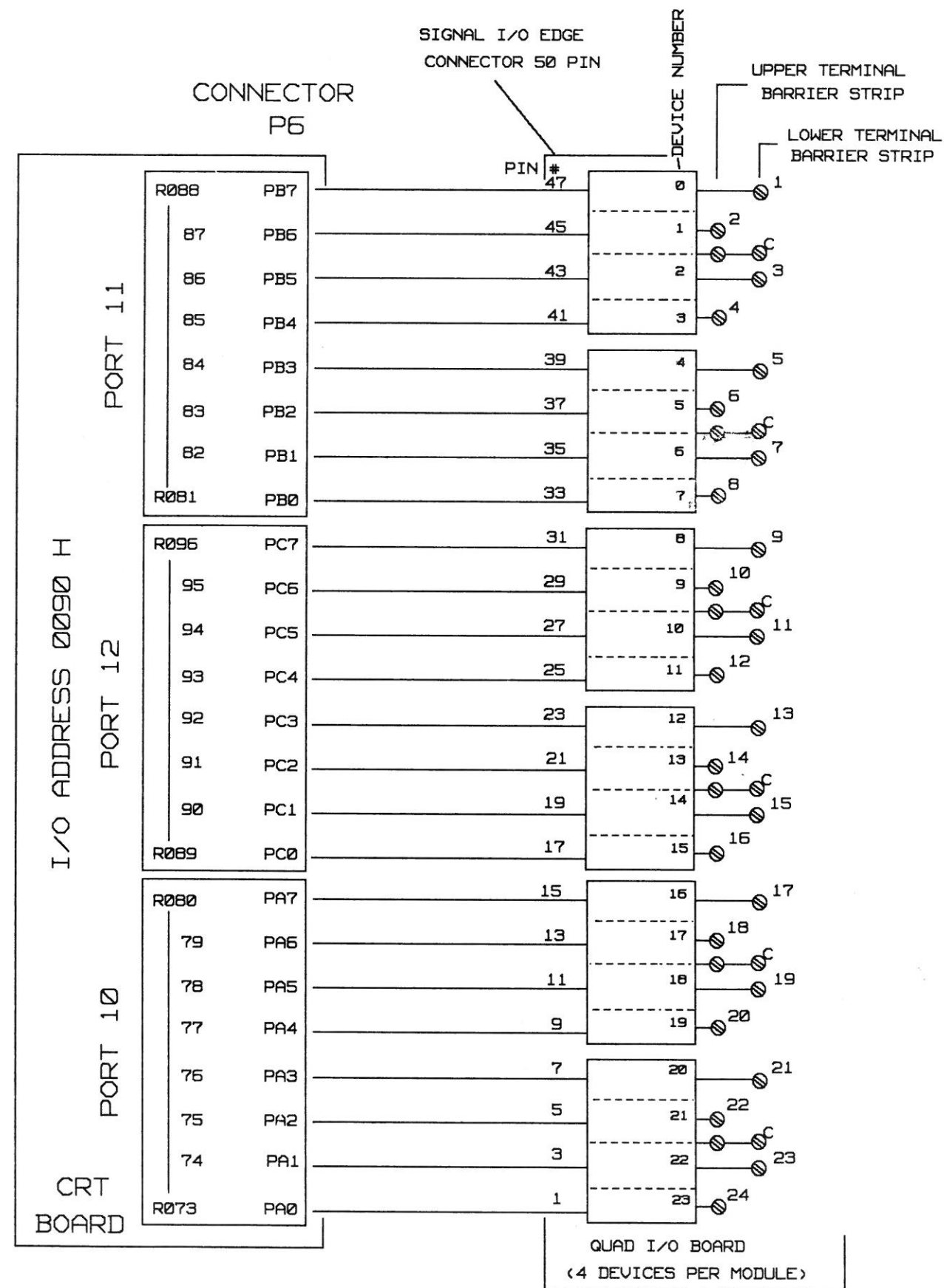
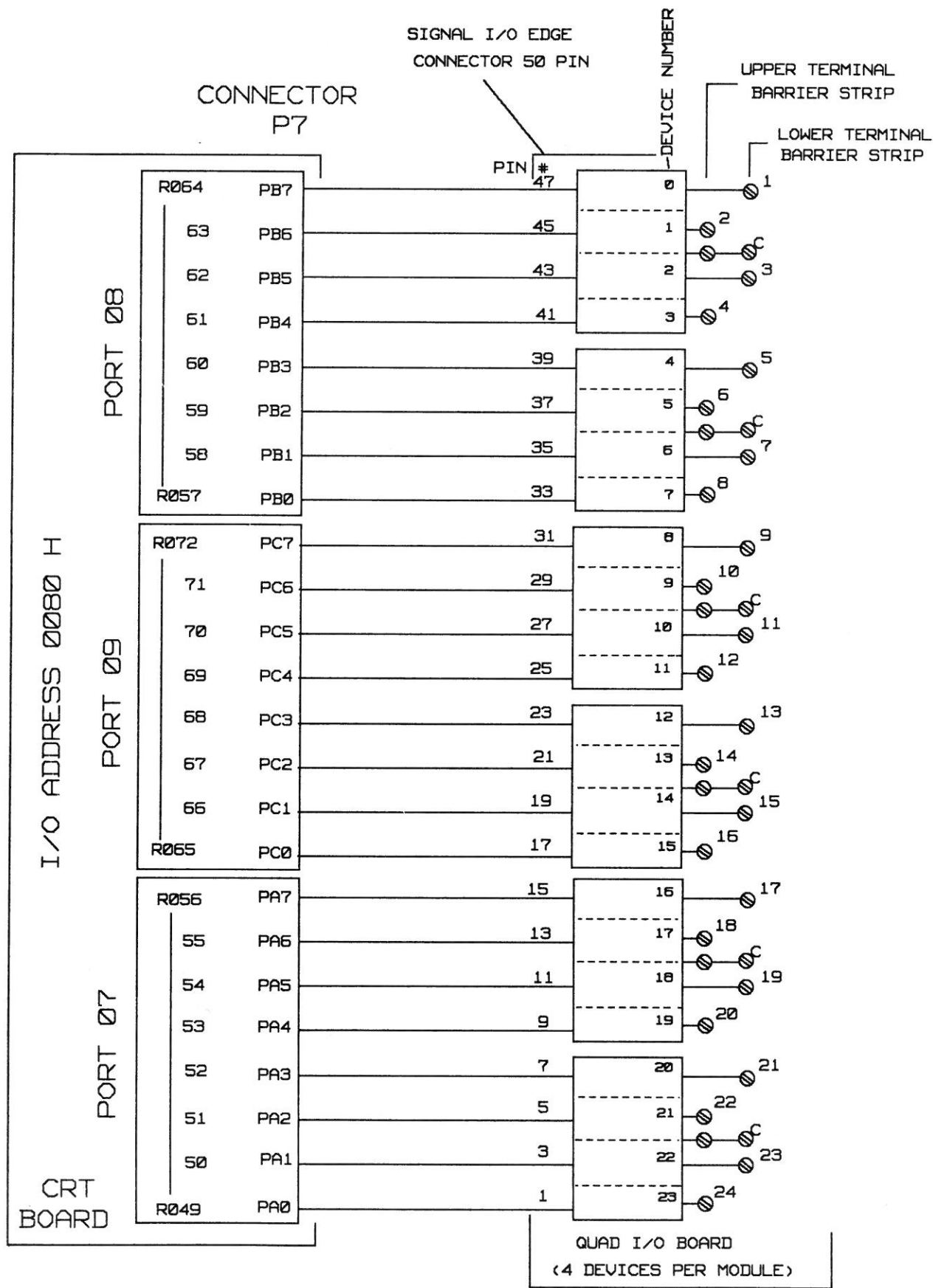

PAL WORKSHEET FOR  
24 PT. QUAD PACK I/O BOARD

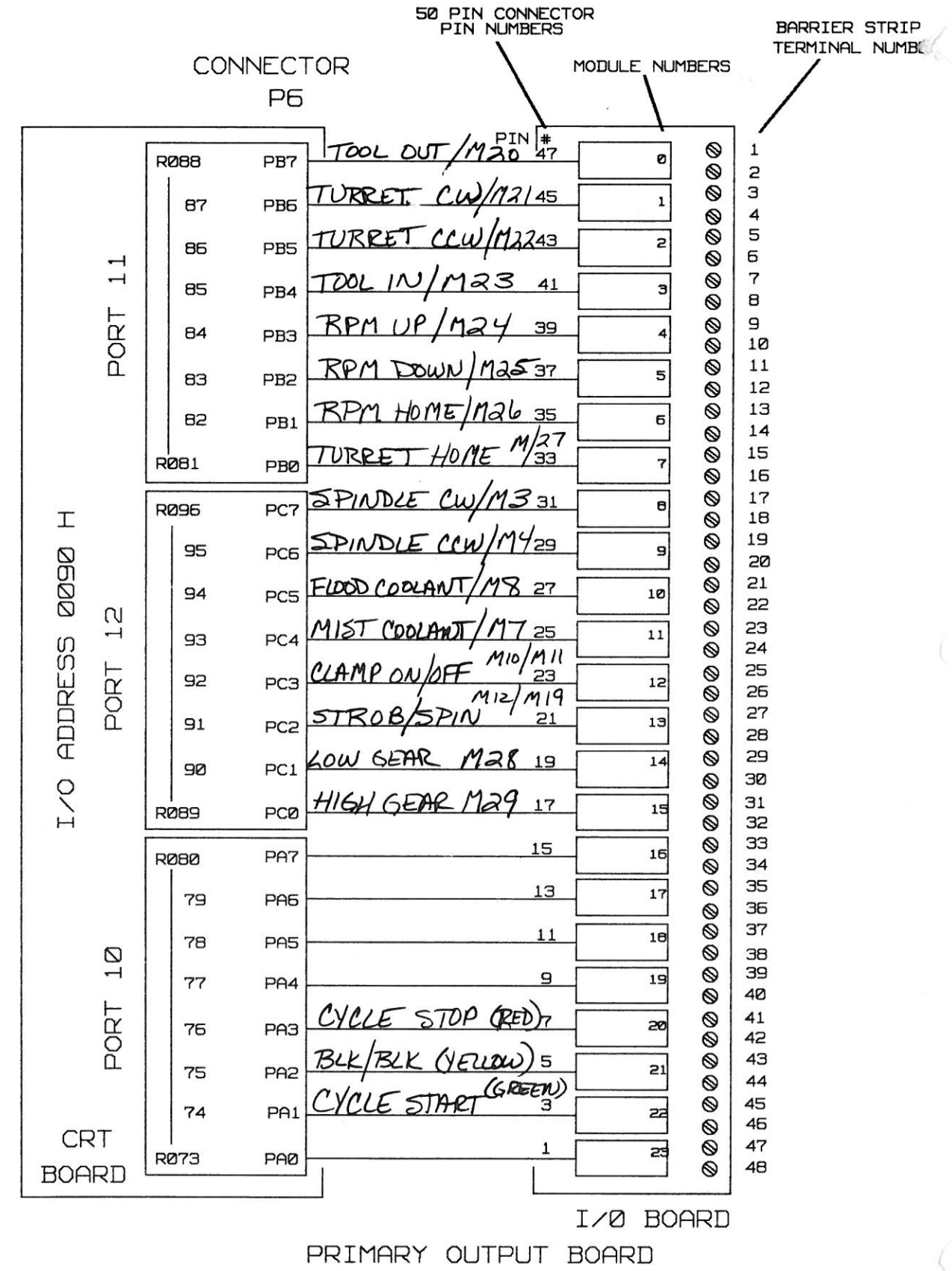
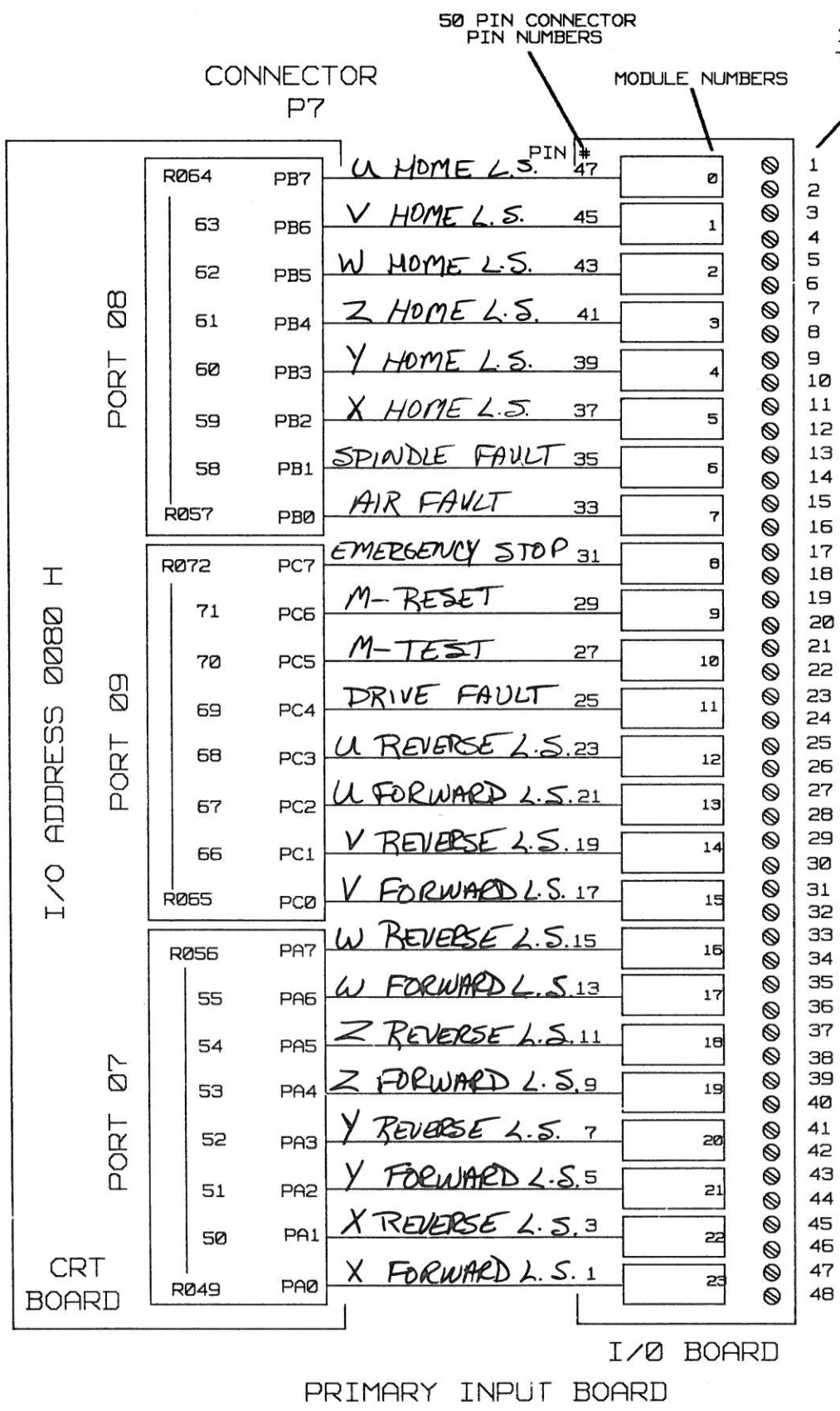

# STANDARD PAL I/O ASSIGNMENTS

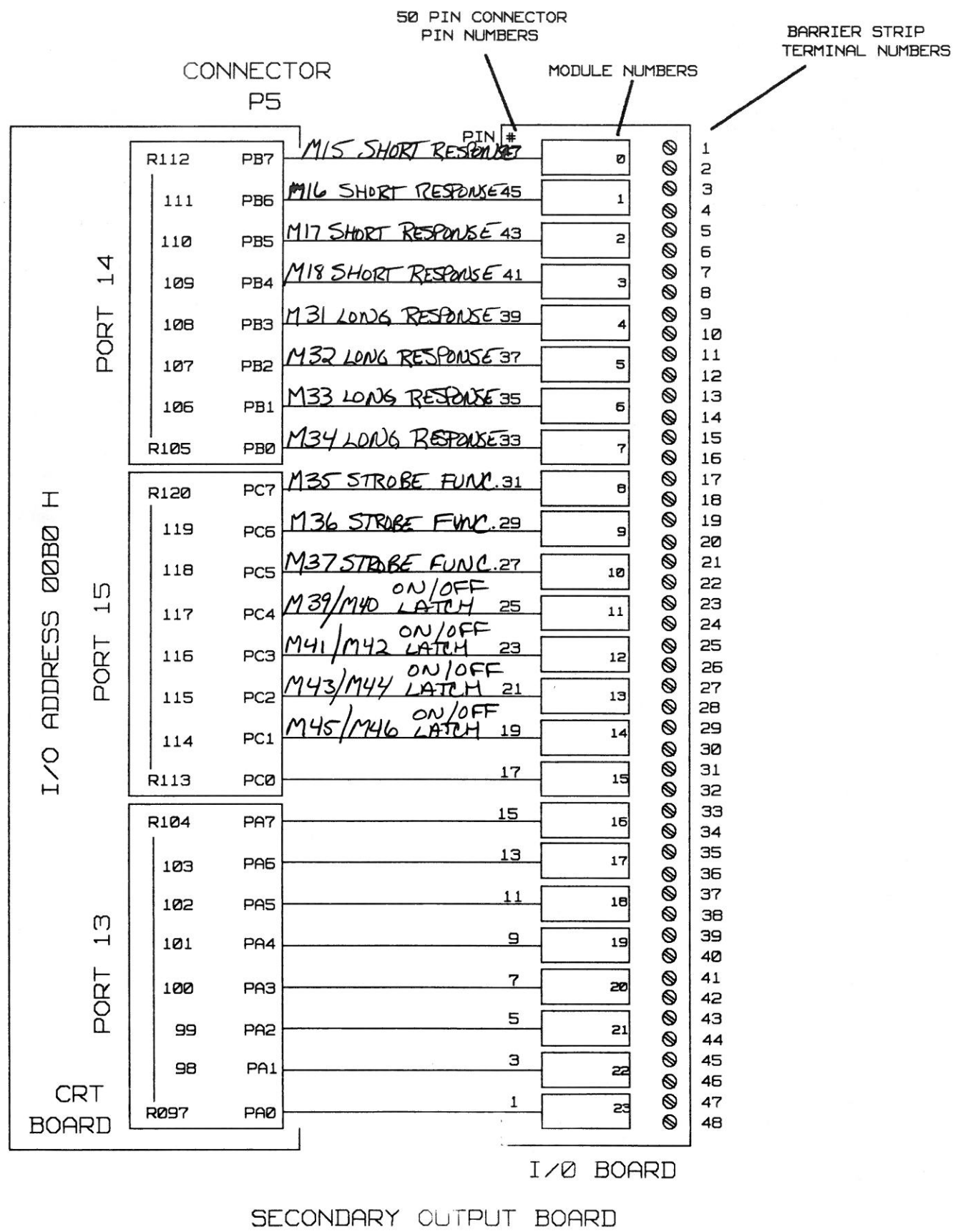

# STANDARD PAL I/O ASSIGNMENTS

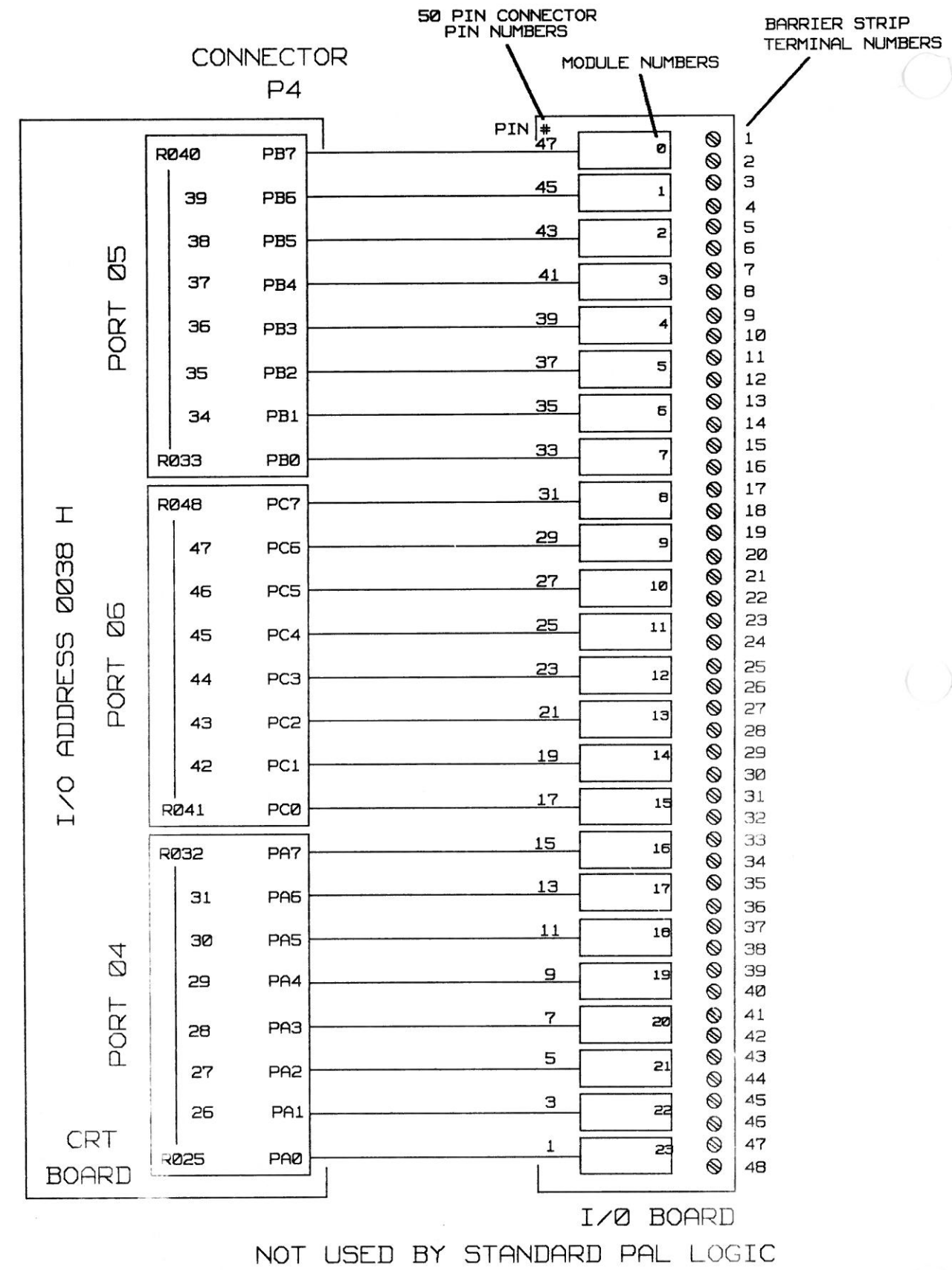
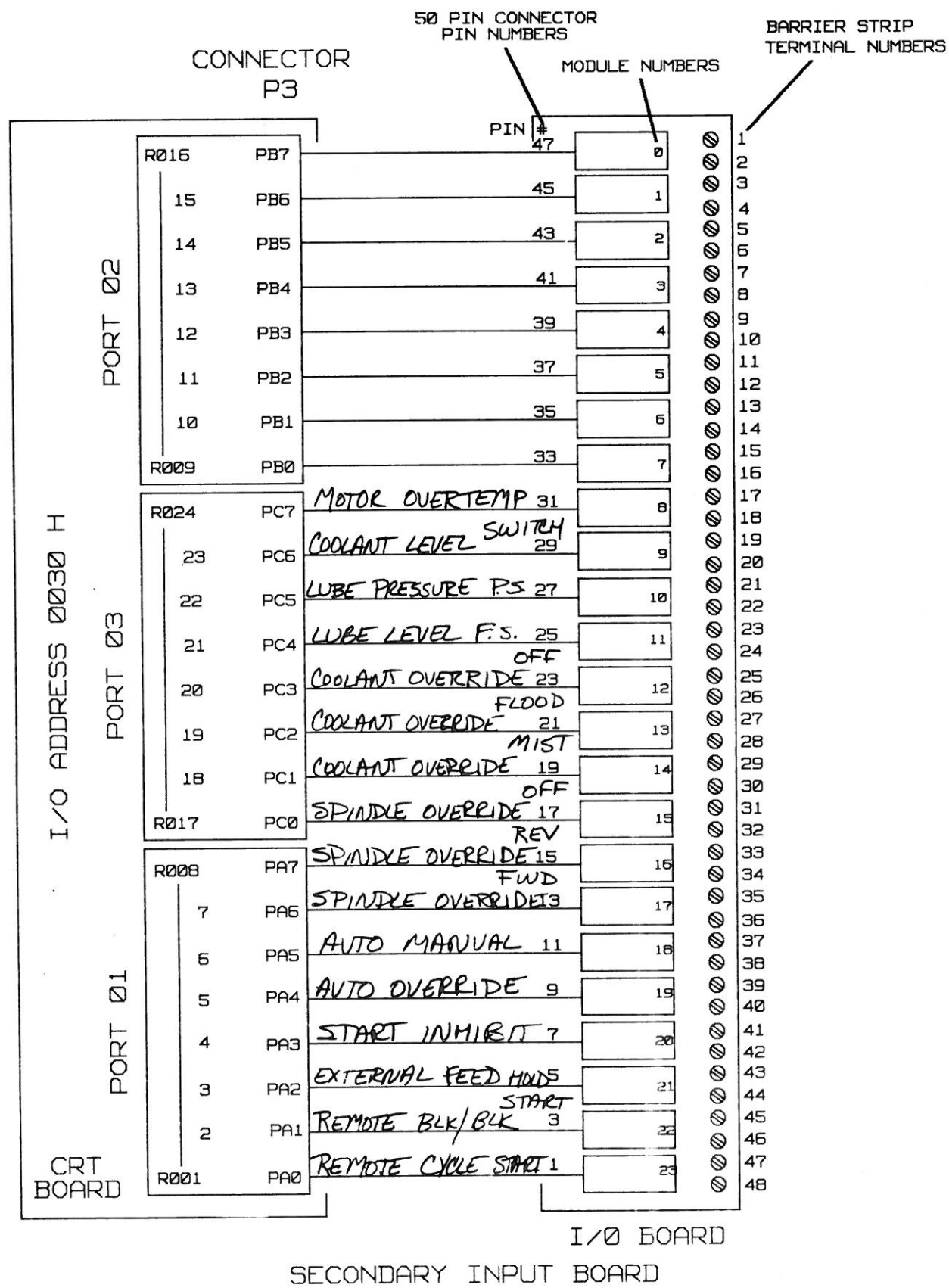

# STANDARD PAL I/O ASSIGNMENTS

Encoder Feedback  
Connections

This drawing illustrates the cabling for interfacing the control to the encoders and optional handwheel (cat. no. 8000 - XHP). Be sure to follow the recommended wire specifications to ensure proper system operation.

Encoder Wiring

For each encoder, you need to provide a #22 AWG cable consisting of 3 twisted pairs, each individually shielded. This cable provides signal paths for channels A, B, and C (marker).

You will also need a #16 AWG cable consisting of a single twisted pair, for each encoder to provide +5V DC power. Maximum cable length is based on the encoder VCC tolerances given by the encoder manufacturer. If the VCC tolerance is 5V DC +/- 5% then the maximum cable length using recommended wiring is 30 feet. If the VCC tolerance is 5V DC +/- 10% then the maximum cable length is 100 feet. We recommend that you keep the encoder cable lengths as short as possible.

All encoder output channels (channels A, B, and C) must be capable of outputting a TTL differential signal into a 470 ohm impedance load. The maximum current drain on the +5V DC terminal is 400 mA. per encoder. However, the total sum of all axis encoder currents must not exceed 1.75 Amps.

The Axis Assignment table provides you with an axis label to connector label cross-reference. There are eight feedback connectors labelled FB0 through FB7 on the CRT board. In systems utilizing the handwheel option, connector FB6 is reserved for handwheel connections.

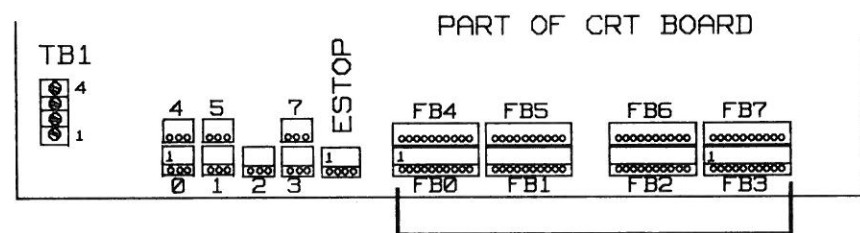

CONNECTOR LABEL	PIN ASSIGNMENT									
	1	2	3	4	5	6	7	8	9	10
FB0, FB1, FB2, FB3, FB4, FB5, FB7	CHANNEL A HI	CHANNEL A LO	SHIELD	CHANNEL B HI	CHANNEL B LO	+5 VDC	GND	SHIELD	CHANNEL C HI	CHANNEL C LO

AXIS ASSIGNMENTS		
CONNECTOR LABEL	AXIS CHANNEL	MP/BANDIT
FB0	0	X AXIS
FB1	1	Y AXIS
FB2	2	Z AXIS
FB3	3	U AXIS
FB4	4	V AXIS
FB5	5	W AXIS
FB6	6	HANDWHL
FB7	7	SPINDLE

ON CRT BOARD

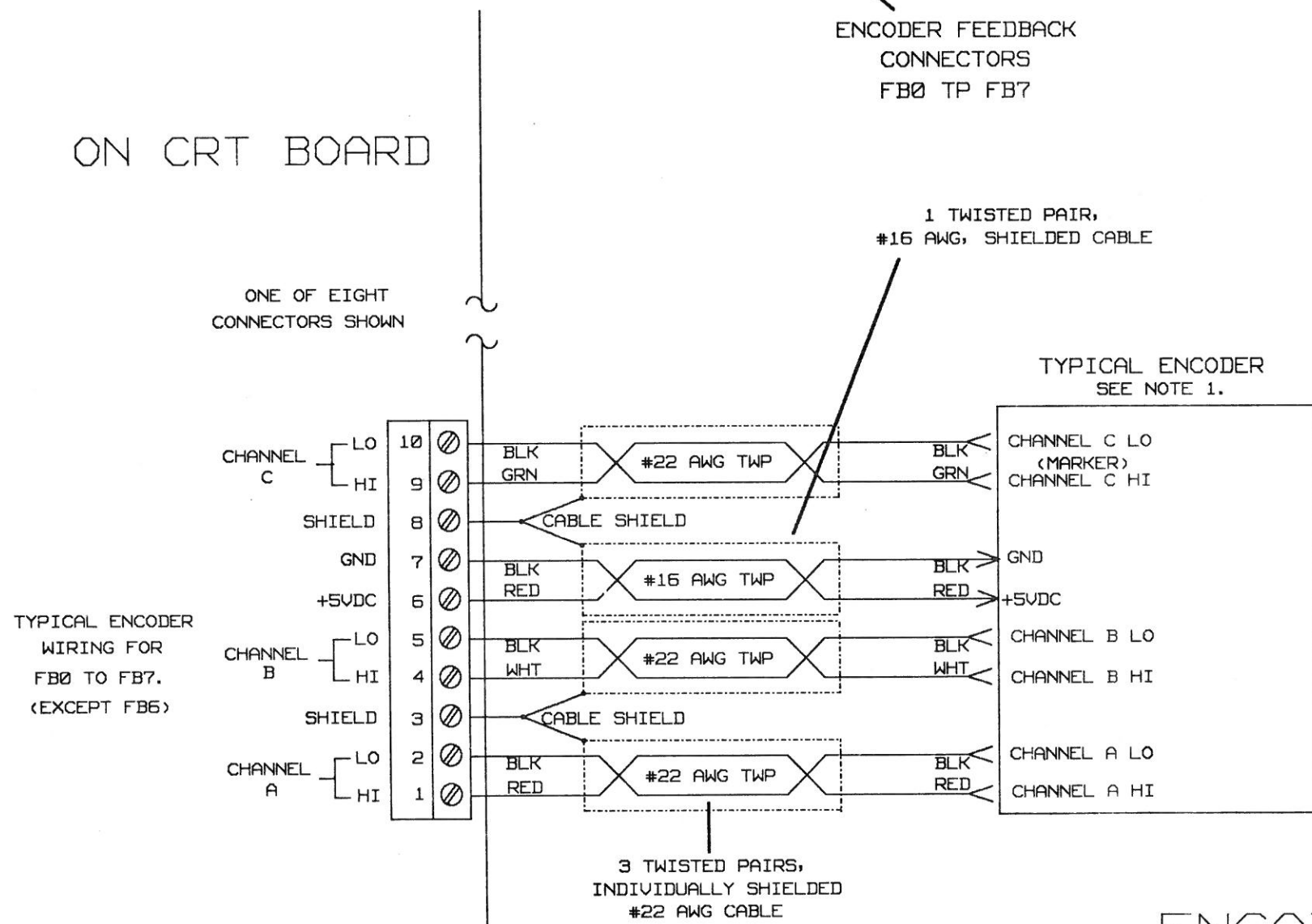

NOTE 1. ALL ENCODER OUTPUTS (CHANNELS A, B, C) MUST BE CAPABLE OF OUTPUTTING A TTL DIFFERENTIAL SIGNAL INTO A 470 OHM IMPEDANCE LOAD. MAXIMUM CURRENT DRAIN ON +5VDC IS 400 MA. PER ENCODER, WHERE TOTAL SUM OF ENCODER CURRENTS ARE NOT TO EXCEED 1.75 AMPS. MAXIMUM CABLE LENGTH BASED ON ENCODER VCC TOLERANCES. IF ENCODER SPEC.: VCC= 5V  $\pm$ 5% THEN MAX. CABLE LENGTH IS 30 FEET. VCC= 5V  $\pm$ 10% THEN MAX. CABLE LENGTH IS 100 FEET. CONSULT ENCODER SPECIFICATIONS TO DETERMINE VCC TOLERANCE.

## ENCODER FEEDBACK CONNECTIONS



## Drive Out Connections

This sheet details the connections between the control package and the user-specified drive amplifiers.

The CRT module has 7 drive out channels with cooresponding connectors. These are labeled DRO through DR7. See the CPU/CRT Connector Location Diagram for connector orientation.

**Important:** Connector DR6 is not used.

An axis assignment chart shows which drive out channels are assigned to which axes in the system. The drive out channels you actually use will depend on the requirements of the application.

You must provide a #22 AWG shielded twisted pair cable for each drive out channel you use. The cable consists of:

- o drive signal wire
- o return wire
- o shield wire -- terminated at the drive out connector

Strip each wire 1/4 in. and twist the strands before you insert them into the drive out connector.

To increase the reliability of the shield connection, prepare the shield wire connection as follows:

1. Twist the shield lead of the cable.
2. Solder a #22 black wire to the twisted shield lead.
3. Cover the connection with heatshrink tubing to prevent accidental shorting.
4. Strip 1/4 in. of insulation from the #22 black wire, twist the strand and insert it into the drive out connector.

The maximum recommended cable length for each drive out channel using #22 AWG cable is 30 feet. Also, the drive load impedance (amplifier input impedance) must be no less than 5K ohms per drive channel. Do not ground the shield of the cable on the drive side.

# CRT BOARD

SEE NOTE 2

## DRIVE OUT CONNECTORS DR0 - DR7

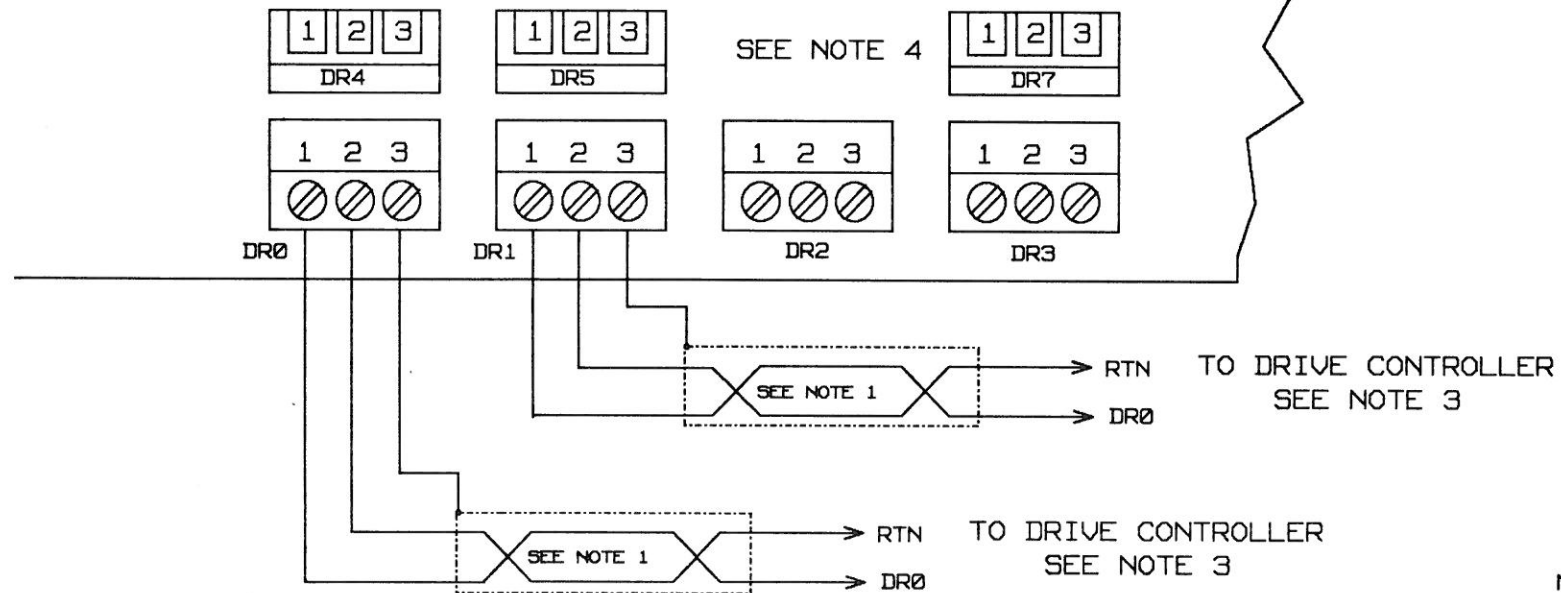

AXIS ASSIGNMENTS		
CONNECTOR LABEL	AXIS	MP/BANDIT
DR0	0	X AXIS
DR1	1	Y AXIS
DR2	2	Z AXIS
DR3	3	U AXIS
DR4	4	V AXIS
DR5	5	W AXIS
DR7 SEE NOTE 4	7	SPINDLE

### TYPICAL WIRING

CONNECTOR PIN ASSIGNMENTS			
CONNECTOR LABEL	PIN 1	PIN 2	PIN 3
DR0	DRIVE OUT 0	RTN	CHASSIS GND
DR1	1		
DR2	2		
DR3	3		
DR4	4		
DR5	5		
DR7 SEE NOTE 4	7	RTN	CHASSIS GND

NOTE 1. USE #22 AWG, SHIELDED, SINGLE TWISTED PAIR CABLE. MAXIMUM CABLE LENGTH IS 30 FEET. TWIST DRAIN WIRES OF CABLE SHIELDS BEFORE INSERTING INTO CONNECTORS.

NOTE 2. SEE CPU/CRT CONNECTOR LOCATION DIAGRAM.

NOTE 3. DRIVE LOAD IMPEDANCE MUST BE NO LESS THAN 5K OHM PER DRIVE CHANNEL.

NOTE 4. CONNECTOR DR6 IS NOT USED.

## DRIVE OUT CONNECTION DIAGRAM

Typical Drive  
Wiring

This drawing gives an overview of the system wiring interconnecting the servo drives to the encoder, motor, and control. This drawing is intended only as a guideline to illustrate the wiring practices we recommend. The drawing represents a simplified one axis system.

When you are integrating the drives to the system, it is important to distinguish whether the drives have differential or single ended inputs:

- o If the drive has a differential input, you need to install a logic ground wire from the drive to the power supply (cat. no. 8400-PSB) LOGIC GROUND terminal. (Refer to the Power Supply Interconnection Diagram.)
- o If the drive has a single ended input, you do not need a logic ground connection.

Be sure the system is properly grounded. Follow the guidelines in the System Grounding section. See the CPU/CRT Connector Location Diagram. Encoder and tachometer cases should be grounded at chassis ground potential. You may have to install external wiring to provide a low resistance path to the chassis ground point. Do not run motor armature wiring in the same wire ways or conduits as encoder cabling. This helps prevent noise interference from being introduced into the encoder cabling through the armature wires.

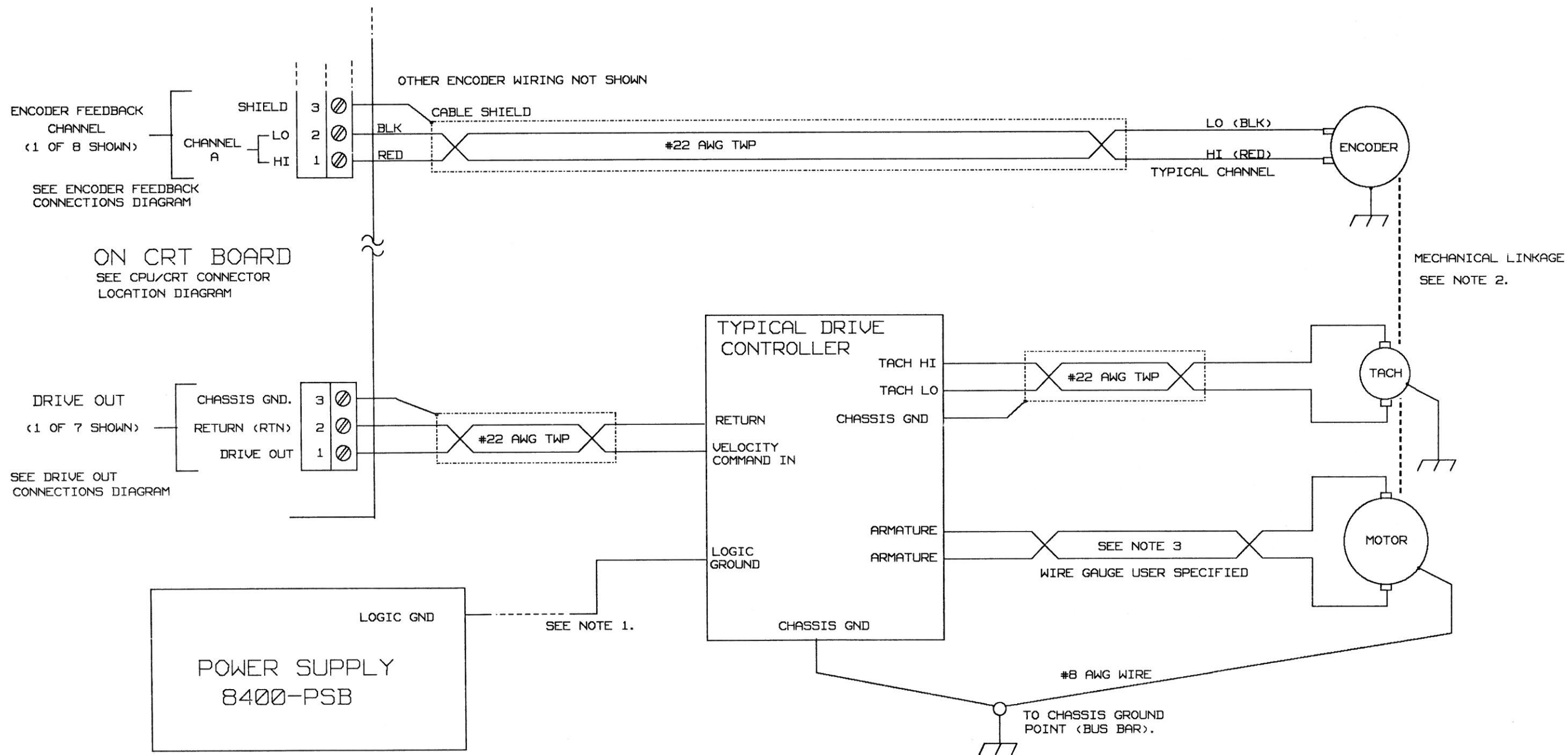

NOTE 1. A LOGIC GROUND CONNECTION IS REQUIRED BETWEEN THE 8400 PSB POWER SUPPLY AND DRIVE CONTROLLER IF A DIFFERENTIAL DRIVE AMPLIFIER IS USED. THIS CONNECTION IS NOT USED FOR SINGLE ENDED AMPLIFIERS.

NOTE 2. INSURE ENCODER AND TACHOMETER CASES ARE AT CHASSIS GROUND POTENTIAL. EXTERNAL WIRING MAY BE REQUIRED TO PROVIDE A LOW RESISTANCE GROUND PATH, WHICH MIGHT NOT BE ACHIEVED THROUGH MECHANICAL LINKAGE.

NOTE 3. DO NOT RUN MOTOR ARMATURE WIRING IN SAME WIRE WAYS OR CONDUITS AS ENCODER CABLING.

TYPICAL DRIVE WIRING DIAGRAM

CABLING

Catalog Number	Length Feet	Description	Connects	
			From	To
8410 ACCB	24.5	AC power cable for pendant	AC terminal	Customer supplied 110V AC power
8410 ACLR	1.5	AC power cable for color monitor	AC terminal strip in pendant	AC connector on color monitor
8410 ACMO	1.5	AC power cable for mono monitor	AC terminal strip in pendant	AC connector on mono monitor
8410 ACBL	1.5	AC power cable for peripheral panel	AC terminal strip in pendant	Peripheral panel
8410 CBBW	22	Video signal cable for mono monitor	BNC connector on monitor	CRT connector on CRT board
8410 CBCC	22	Video signal cable for color monitor	Connector on CRT	CRT connector on CRT board
8410 CBES	22	E-Stop cable	E-Stop switch	E-Stop input (PAL defined) on input board
8410 CBHW	22	Handwheel cable	D-Shell end connects on handwheel	Connector FB6 on CRT board
8410 CBKY	22	Serial keyboard cable	PC on front panel board	PT on CPU board
8410 CBPL	22	Indicator light cable	P7 on front panel board	Indicator light outputs (PAL defined) on output board
8410 SCBL	22	Serial communications cable	D-Shell end mounts to peripheral panel (or customer selected location)	P3 or P4 on CPU board

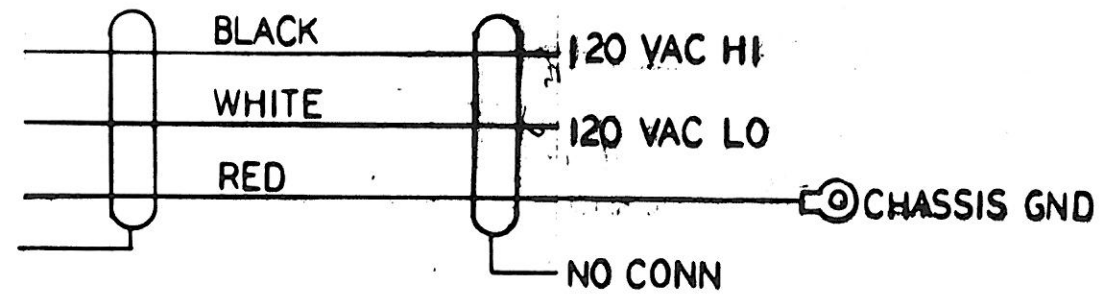

To customer  
supplied AC Power  
Source.  
See the AC Power  
Distribution  
Diagram.

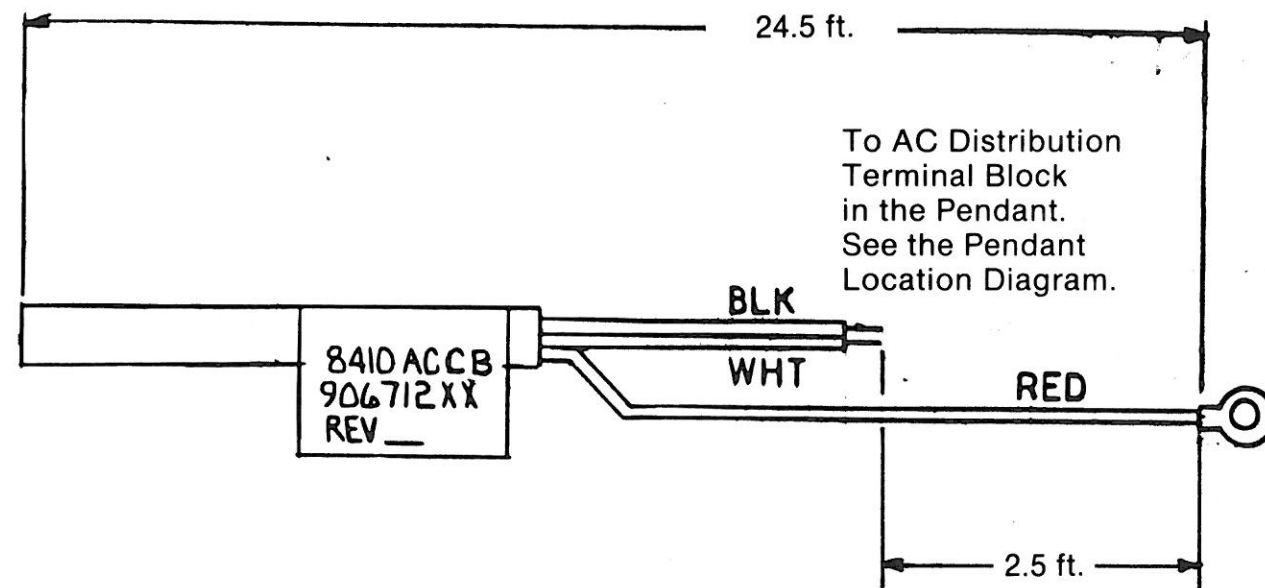

**AC Cable for Incoming  
Power to AC Distribution  
Terminal Block in Pendant.  
Catalog Number 8410-ACCB.**

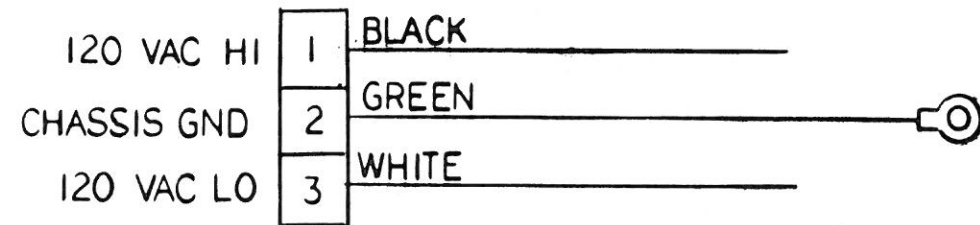

To AC connector on color CRT. See Color Monitor Connections and Location Diagram.

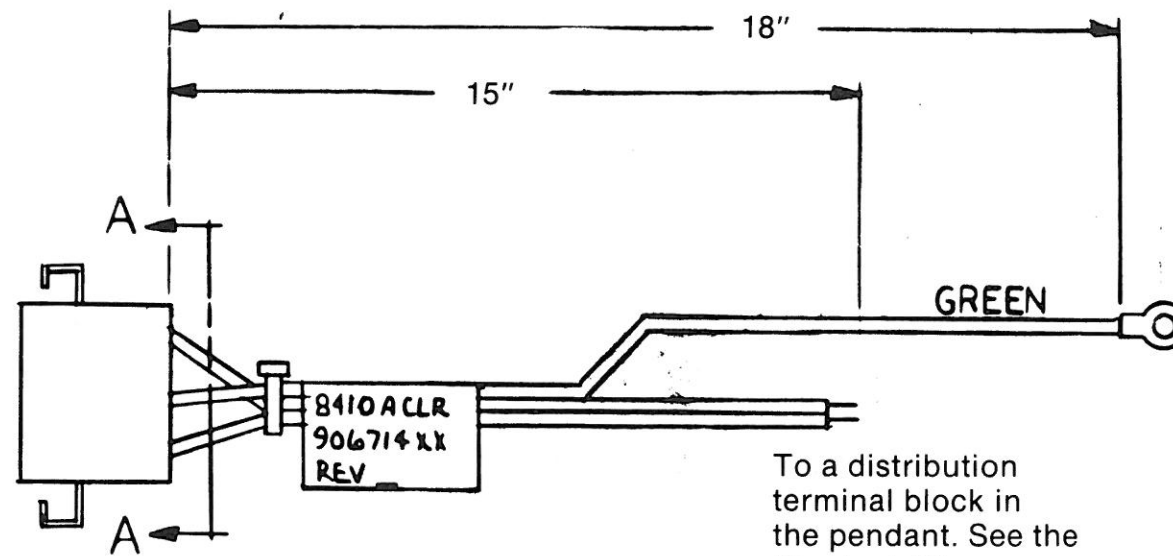

To ground stud on top of the pendant. See the Pendant AC Terminal Block Connections Diagram.

To a distribution terminal block in the pendant. See the Pendant AC Terminal Block Connections Diagram.

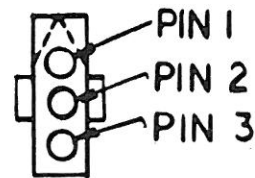

VIEW A-A

## AC Power Cable for Color Monitor Catalog Number 8410-ACLR

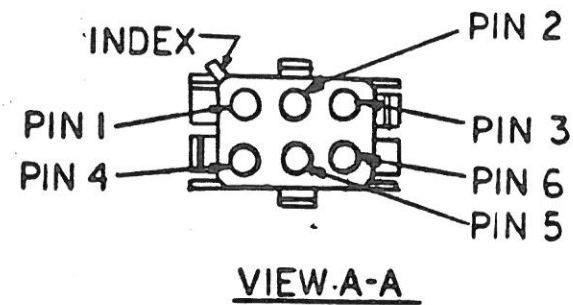
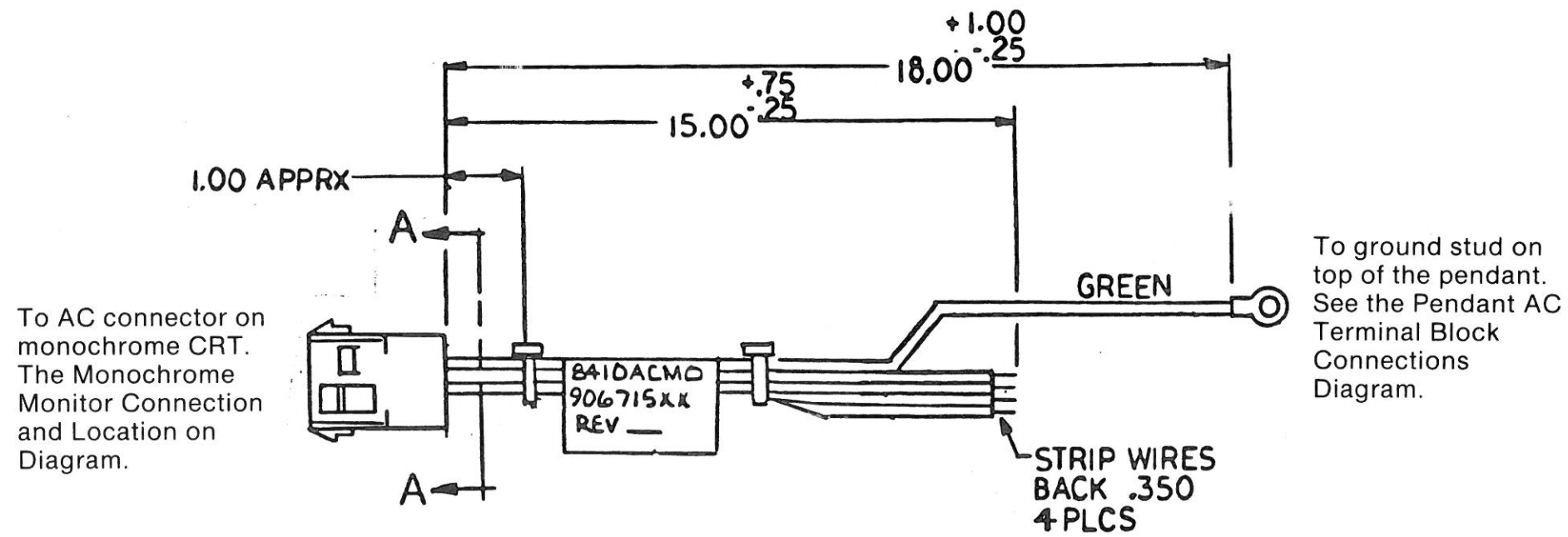
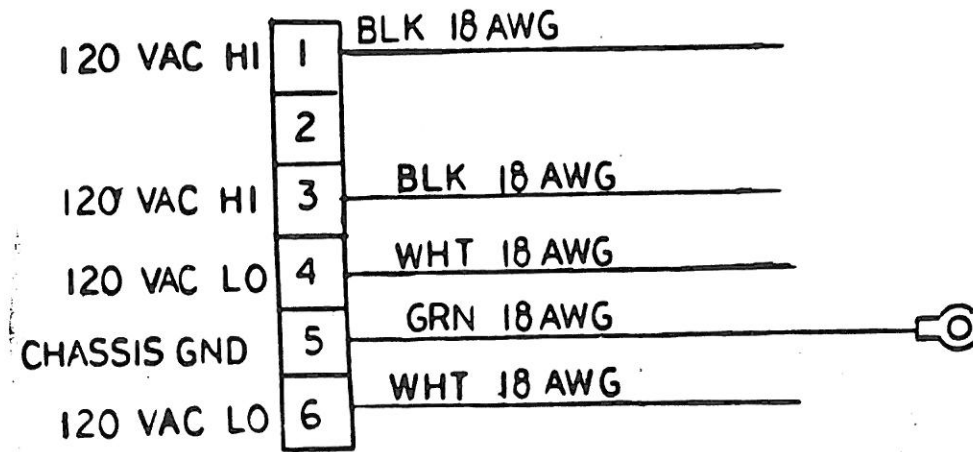

To AC distribution terminal block in the pendant. See the Pendant AC Terminal Block Connections Diagram.

## AC Power Cable for Monochrome Monitor Catalog Number 8410-ACMO



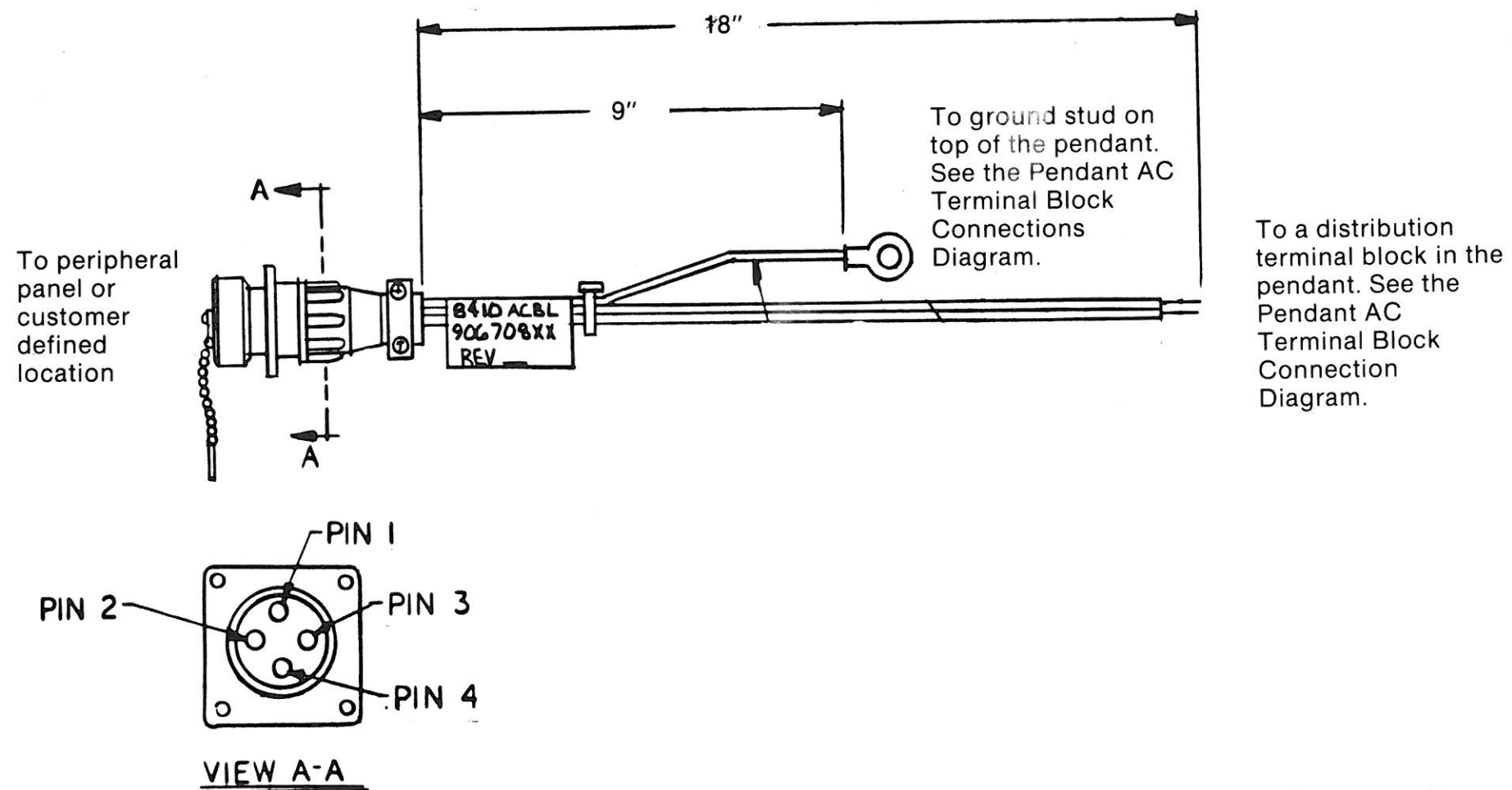
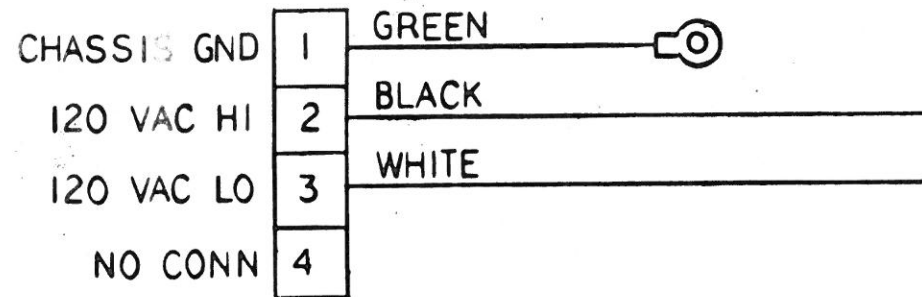

AC Cable for  
Peripheral Panel  
Catalog Number 8410-ACBL

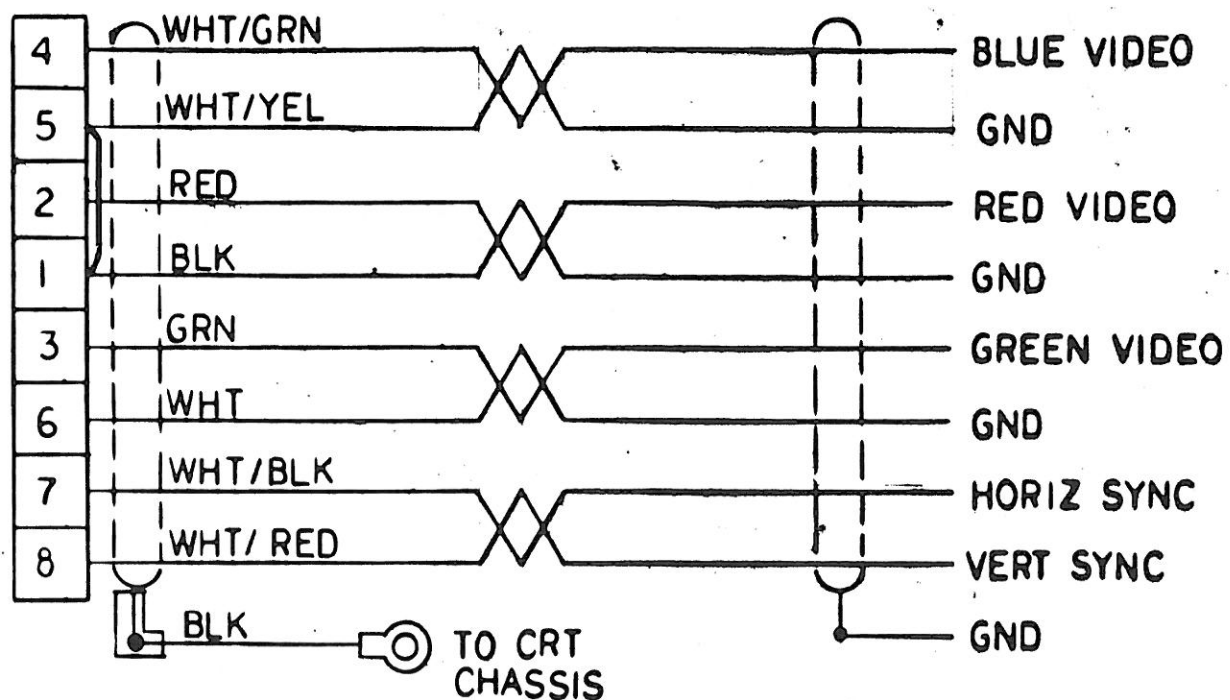

Video signal connector on the color CRT. See the Color Monitor Connections and Location Diagram.

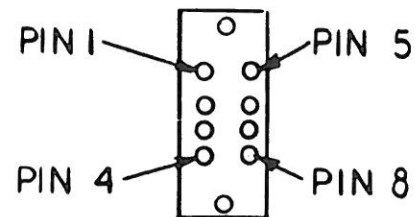
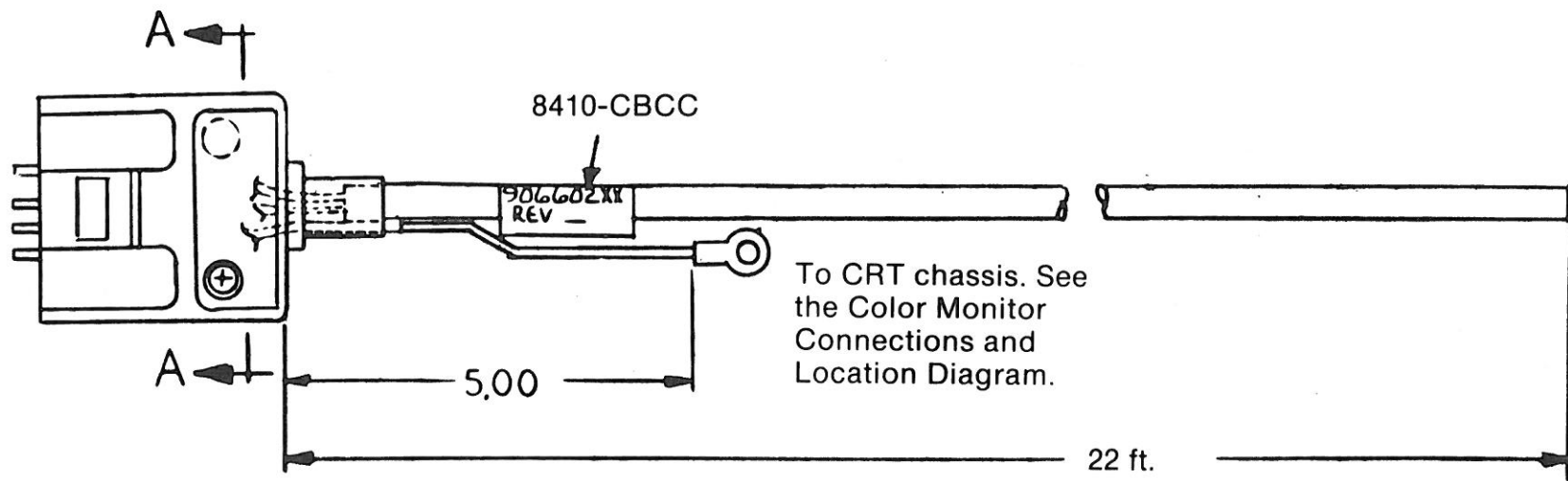

VIEW A-A  
(BACK OF CONNECTOR)

## Video Signal Cable for Color Monitor Catalog Number 8410-CBCC

To monochrome  
CRT BNC connector  
(75 ohms). See the  
CRT Video Signal  
Connection  
Diagram.

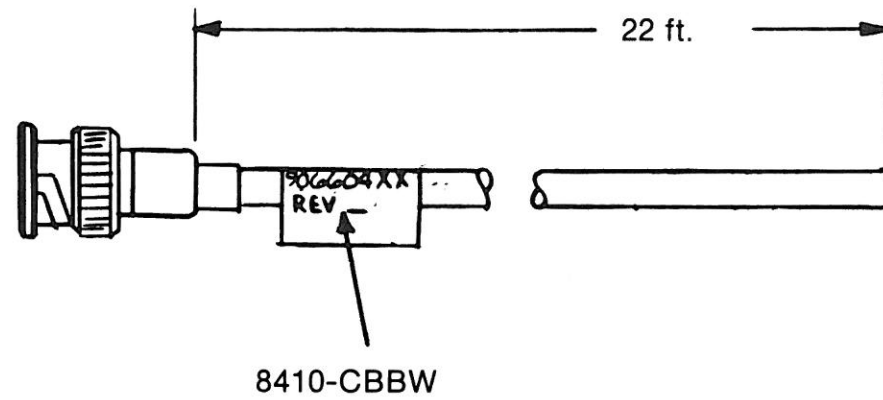

To CRT connector  
on processor CRT  
board. See the CRT  
Video. Signal  
Connection  
Diagram.

Video Signal Cable  
for Monochrome Monitor  
Catalog Number 8410-CBBW

To user defined E-stop string or E-Stop (PAL Defined) on the input board. See the Typical E-stop Wiring Diagram. (If B4 standard ladder is used, see the standard PAL I/O assignments.

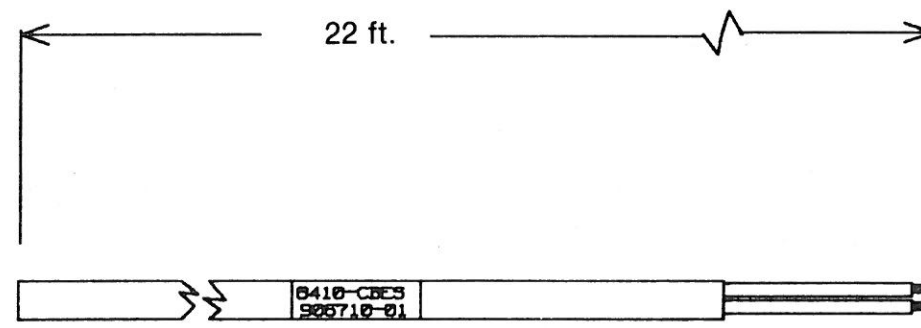

To E-stop switch. See the Pendant Location Diagram and the Typical E-stop Wiring Diagram.

## E-Stop Cable Catalog Number 8410-CBES

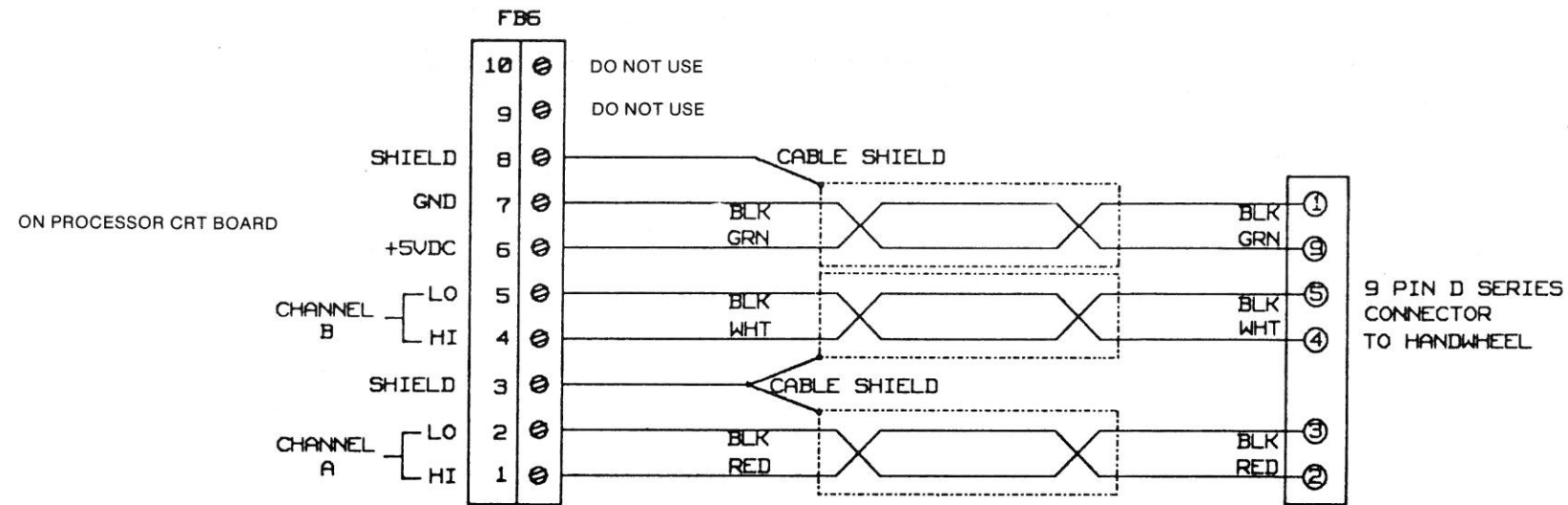

To FB6 on processor CRT board. See the CPU/CRT Connector Location Diagram for the location of the connector.

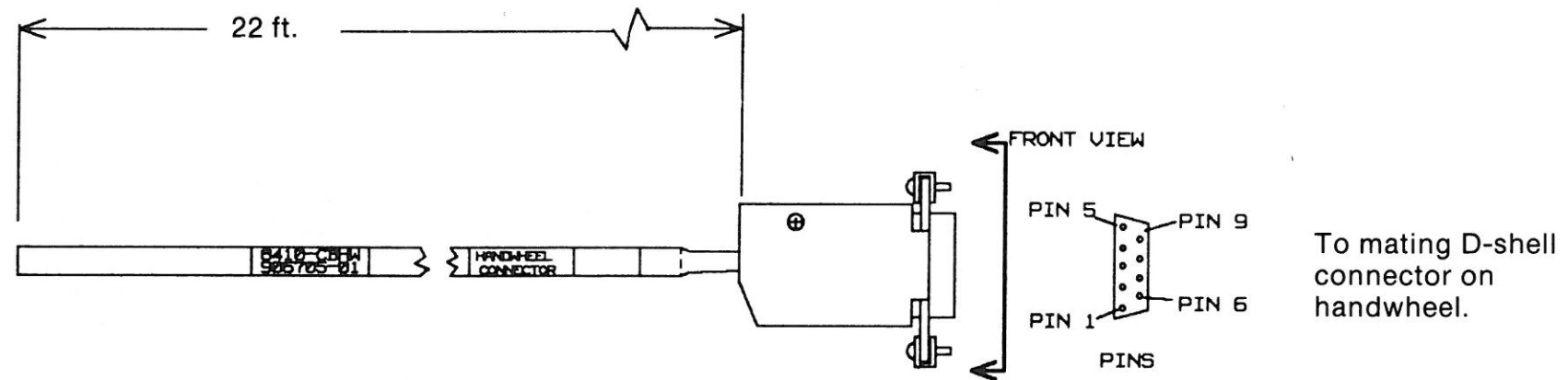

Handwheel cable  
Catalog Number 8410-CBHW

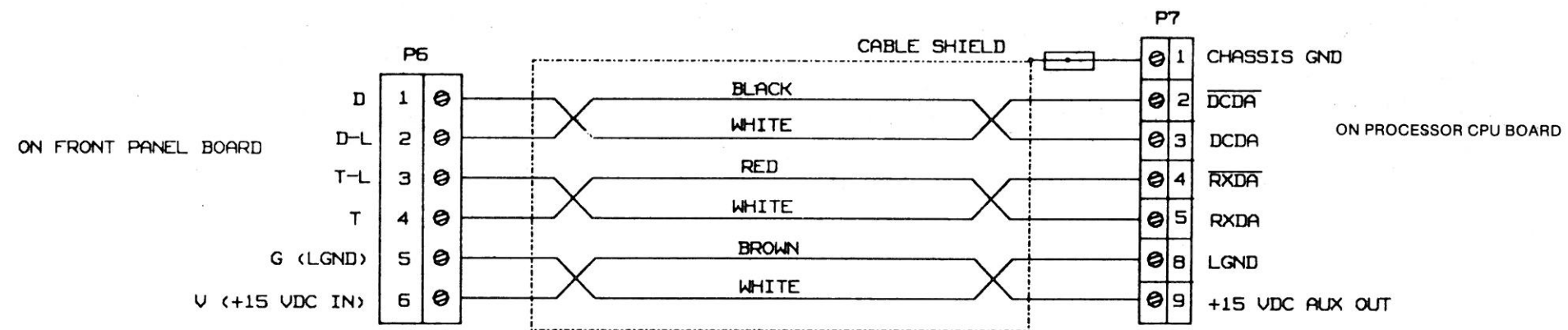

To connector P6 on the front panel board. See the Pendant Location Diagram for the location of the connector.

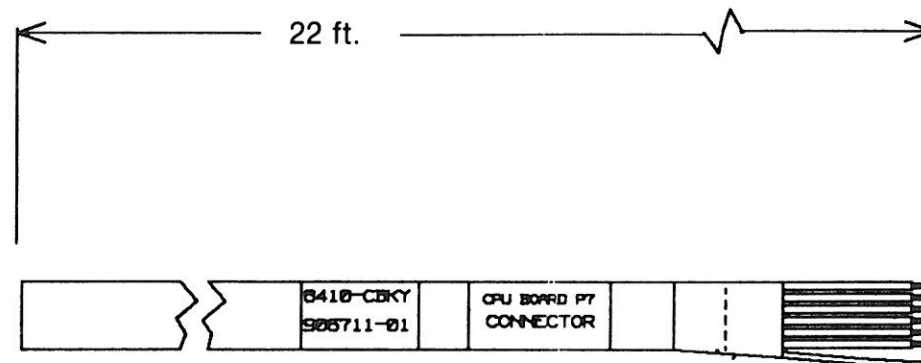

To connector P7 on processor CPU board. See the CPU/CRT Connector Location Diagram for the location of the connector.

Serial Keyboard cable  
Catalog Number 8410-CBKY

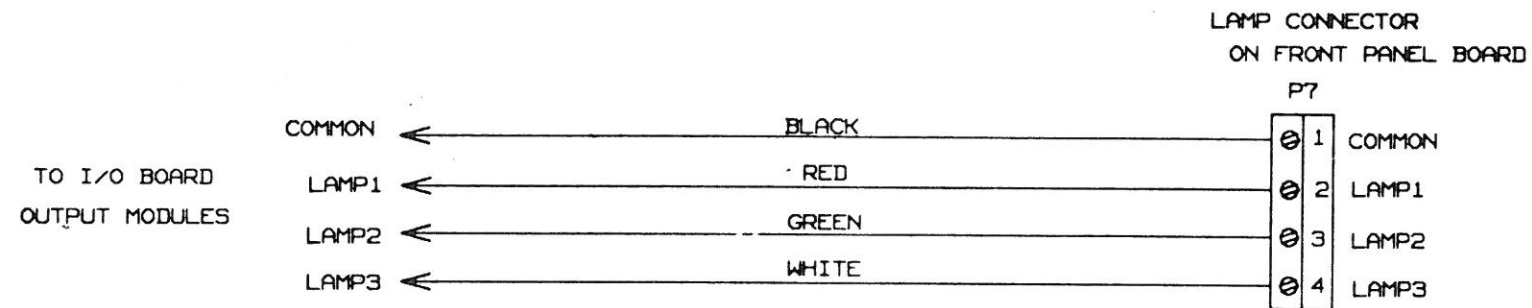

Cycle start, blk/blk, cycle stop indicator light outputs (PAL defined) on output board. If B4 standard ladder is used see the Standard PAL I/O assignments.

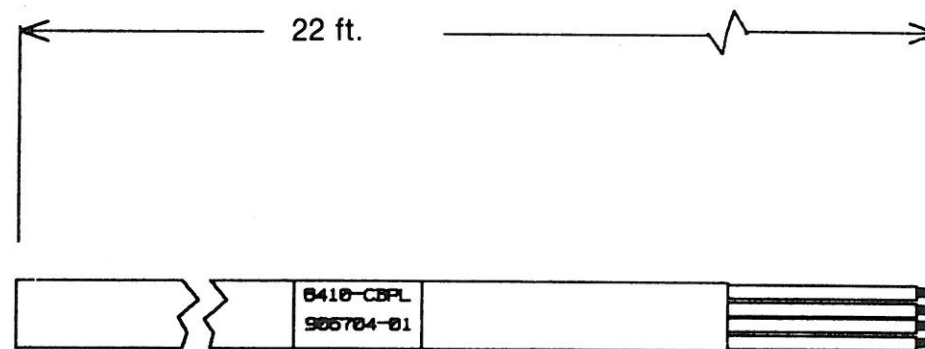

To connector P7 on front panel board. See the Pendant Location Diagram for the location of the connector.

**Indicator Light Cable**  
**Catalog Number 8410-CBPL**

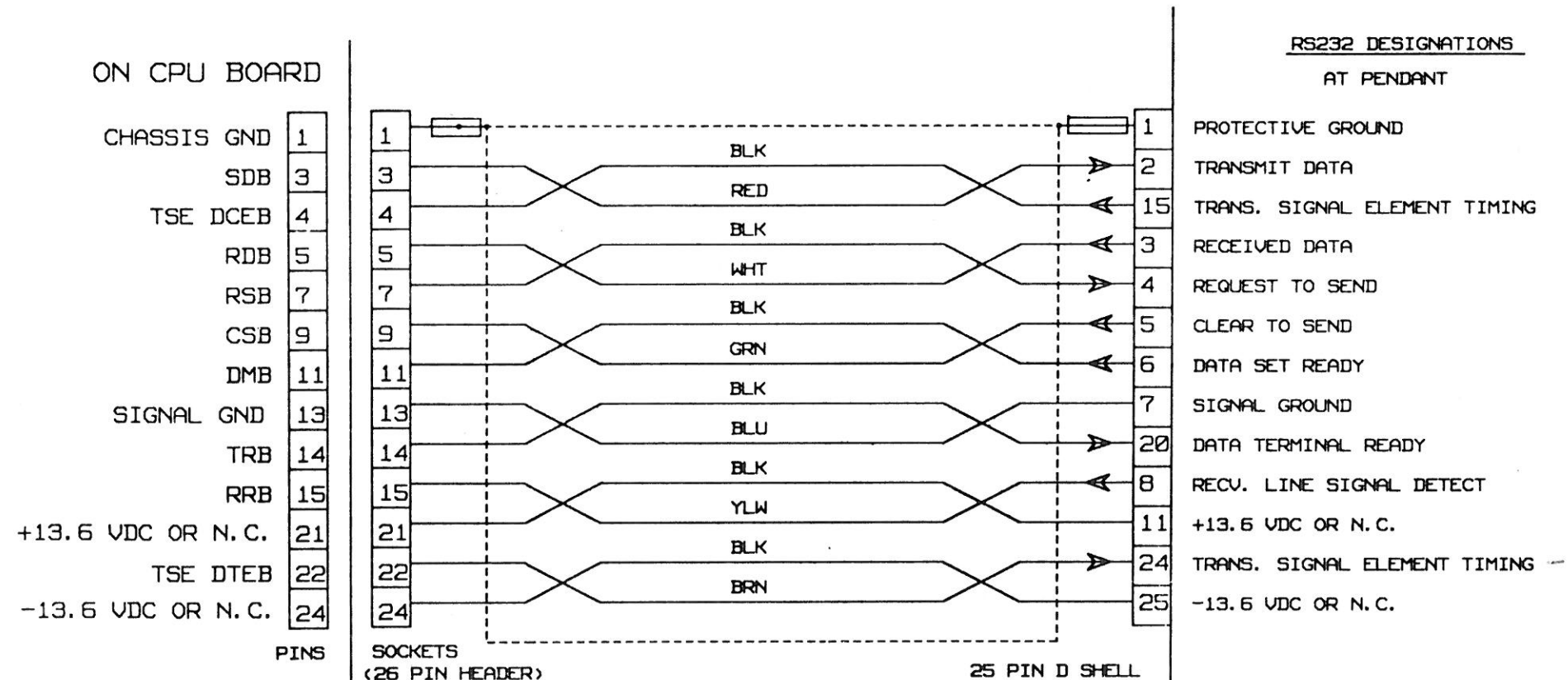

To connector P3 or P4 on CPU board. See the RS232 Cabling To Pendant.

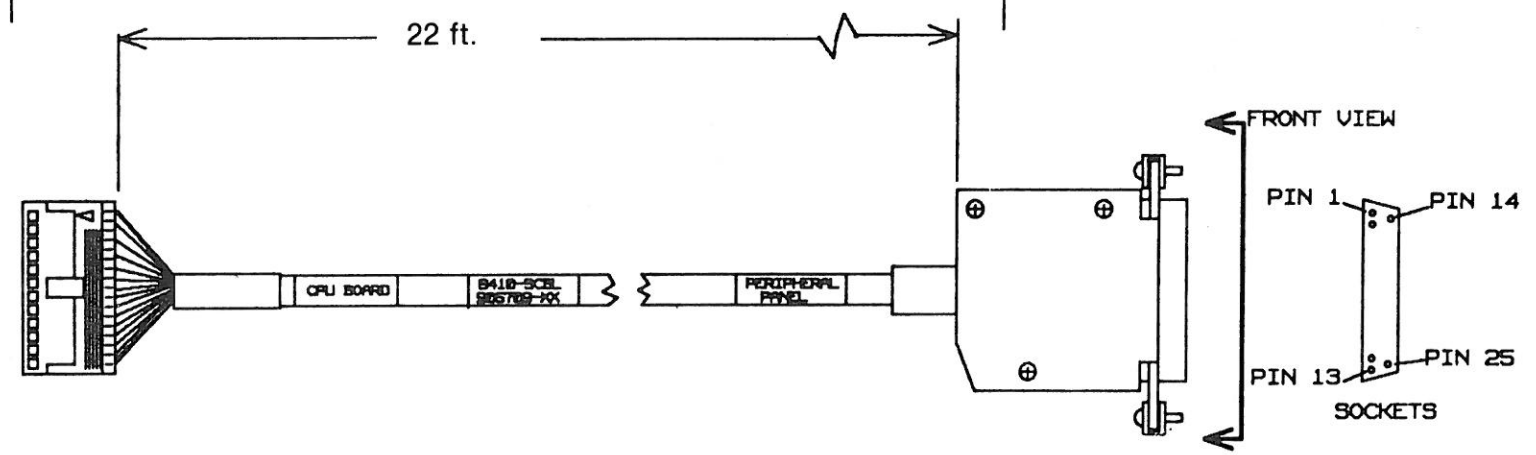
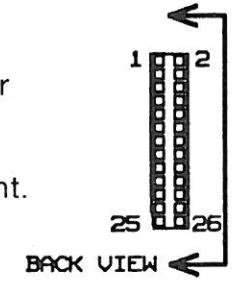

To peripheral panel or customer defined location

# Serial Communications Cable Catalog Number 8410-SCBL



Configuring  
Velocity Loop

To configure the velocity loop (drive out signals) correctly, use the following procedure:

1. Put positive voltage to the drive input with the battery box.
2. Make sure the axis moves in a positive direction. If your axis travels in a negative direction in a controlled manner, then switch both the armature and tachometer wires.

Important: If your axis oscillates or runs away, then switch only the tachometer wires. Apply voltage to the drive again and make sure the axis moves in the proper direction.

## Encoder Wiring

Use this procedure to check your encoder's wiring before you begin running the machine:

**Warning:** To guard against personal injury and/or damage to the machine, be sure to power down the control before swapping encoder wires. If the control is not powered down when the encoder wires are switched, the axes could run away.

1. Wire the encoder to the control as shown in the drawing.
2. Power up the control and keep the system in E-Stop during these operations.
3. With an oscilloscope or digital voltmeter, verify that  $A_{HI}$  and  $A_{LO}$  are complements. That is, when  $A_{HI}$  is high then  $A_{LO}$  is low and vice-versa. Next, check channels B and C (marker).
4. Monitor channel  $C_{HI}$  (marker  $HI$ ). This channel should be low throughout the full rotation of the encoder except for one high-going interval at the marker. If this is not the case, swap channel  $C_{HI}$  and  $C_{LO}$  and recheck the channel.
5. Manually turn the encoder until it is on the marker, that is, channel  $C_{HI}$  is high. With  $C_{HI}$  high, look at  $A_{HI}$ .  $A_{HI}$  must also be high. If it is not, swap  $A_{HI}$  with  $A_{LO}$ . With  $C_{HI}$  high, check  $B_{HI}$ .  $B_{HI}$  must be high, if it is not, swap  $B_{HI}$  with  $B_{LO}$ . Verify that  $A_{HI}$  and  $B_{HI}$  are high when  $C_{HI}$  is high.
6. Manually turn the axis in the positive direction while viewing channels  $A_{HI}$  and  $B_{HI}$  on the oscilloscope. Channel  $A_{HI}$  must lead channel  $B_{HI}$  as shown. If this is not so, swap  $A_{HI}$  with  $B_{HI}$ , and  $A_{LO}$  with  $B_{LO}$ . Check the phasing again to be sure it is correct.

## ENCODER PHASING, P1

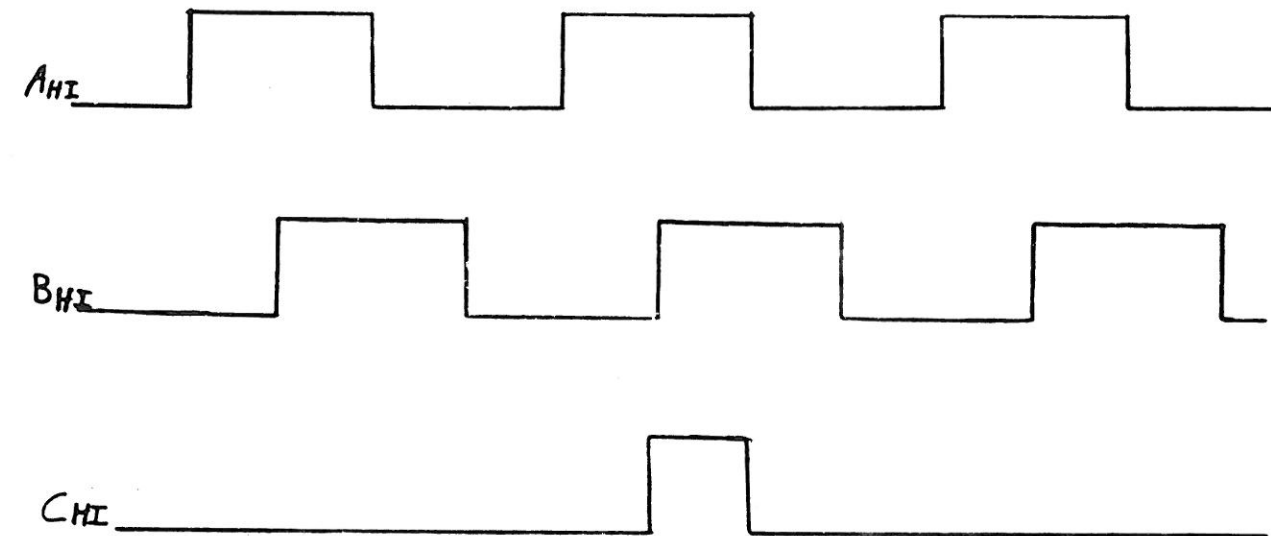

The above diagram shows the required encoder signals for movement in the positive direction for each axis. Note that Channel  $A_{HI}$  leads  $B_{HI}$ .

The marker channel  $C_{HI}$  must be high true as shown, and must be high while both Channel  $A_{HI}$  and  $B_{HI}$  are Both HI.

Control  
Power-Up

Before you power-up your control, make sure that battery jumper E3 located on the CPU board is in the "on" position. See drawing 3, The CPU/CRT Board Layout, for more details.

---

To power-up your control:

1. Be sure the control is in ESTOP, then restore the system power.
2. The control firmware powers-up in a STANDBY mode with a blank screen. The power-up sequence is finished when the red Cycle Stop pushbutton lights up and the condition of the two status LEDs (next to the Power On LED) on the control package changes from solid to flicker. Press the [EXIT] key when the power-up sequence is finished. This brings up the main page.
3. Refer to the User's Manual for power-up with an Access Code instead of power-up with a main menu.







**ALLEN-BRADLEY**

**Industrial Computer Group — CNC Division**  
747 Alpha Drive  
Highland Heights, Ohio 44143